



LOFTWARE
ENTERPRISE LABELING SOLUTIONS



Loftware Connector® for SAP® Applications

Version 2.0

Installation Guide

© 2011. March. All rights reserved. Version 2.0 Rev A

Loftware, LLM, Loftware Label Design, Loftware Print Server, LPS, Loftware Connector, Global Marking Solutions, I-Push, and I-Pull are all registered trademarks of Loftware, Inc. Loftware WebAccess, LWA, and Loftware Web Services are trademarks of Loftware, Inc.

Loftware, Inc., 166 Corporate Drive, Portsmouth, NH 03801
Phone: 603.766.3630
Fax: 603.766.3631
sales@loftware.com
www.loftware.com



Contents

Contents.....	2
Contact Loftware.....	5
Licensing, Warranty, and Support.....	6
Technical Support.....	7
About the Loftware Connector for SAP Applications.....	9
Loftware Connector for SAP Applications Print Process.....	9
Install Overview.....	11
Loftware Connector for SAP Server.....	11
Loftware Enterprise Update.....	11
Loftware Connector for SAP Configuration.....	11
Installation Requirements.....	12
Operating System.....	12
Browser.....	13
Loftware.....	13
Third Party.....	13
Microsoft Internet Information Services (IIS).....	14
Microsoft .NET Framework.....	15
SAP Connectivity and Security.....	16
Deployment Scenarios.....	18
Non-Clustered Deployments.....	18
Clustered Deployments.....	20
Install the Loftware Connector for SAP Applications.....	23



Install Software Enterprise Update on a Remote Software Print Server System.....	24
Install the Software Connector for SAP Applications Configuration User Interface on a Remote Server.....	27
Register your Software Connector for SAP.....	29
Upgrading from the Software Connector for SAP version 1.5.x to the Software Connector for SAP Applications version 2.0.....	31
Install the Software Connector for SAP Applications on a Failover Cluster.....	32
Cluster Installation Requirements.....	32
Configuration Files.....	32
Install on a Cluster.....	33
Cluster Server Error.....	33
Post Installation.....	35
Activating the Server License.....	35
Enable Scripting in Client Browsers.....	35
Configuring the Connection.....	36
Configuring RDI.....	36
Starting the Services.....	36
Software Enterprise Update.....	38
LwEntUp.exe.config.....	38
Application Settings.....	38
The Software Connector for SAP Applications BC-XOM Connection.....	44
RDI Interface Architecture.....	46
Configuring the Software Connector for SAP Applications.....	47
Configuring the Software Connector for SAP Applications Command Line.....	62
Configuring SAP.....	64
Software Connector for SAP Applications web.config.....	74
SAP ABAP Requirements for Label Printing.....	78



RFC Destination.....	78
Communication Modes.....	81
Data Types.....	83
Stacking Label Requests.....	85
Exceptions.....	85
SAP ABAP Confirmation Values.....	86
Implementation Considerations.....	91
Troubleshooting.....	92
Uninstall the Loftware Connector for SAP Applications.....	94
Loftware Connector for SAP Applications Configuration and Diagnostics.....	95
Open the Loftware Connector for SAP Applications Configuration and Diagnostics Interface.....	95
Defining Labels, Label Types, and Label Groups.....	97
Defining Rules.....	103
Edit Servers.....	115
System Configuration.....	117
Format Path Definition.....	118
Processing a Print Request.....	120
Diagnostics.....	120



Contact Loftware

Loftware, Inc.
166 Corporate Drive
Portsmouth NH 03801
U.S.A.

Professional Services

For consultation, implementation services, training or product optimization please contact Loftware's Professional Services Group.

Phone +1.603.766.3630 x209

E-mail psg@loftware.com

Technical Support

For installation and configuration questions, please contact Loftware's Technical Support department. Visit www.loftware.com for Loftware's technical support policies.

Phone +1.603.766.3630 x402

Fax +1.603.766.3635

E-mail support@loftware.com

Customer Service

For licensing, product information, and ordering questions, please contact Loftware's Customer Service department. Please have your Serial Number and Registration information available, so we can provide service to you quickly and efficiently.

Phone +1.603.766.3630 x401

Fax +1.603.766.3631

E-mail customerservice@loftware.com



Licensing, Warranty, and Support

The following documents are available on the CD-ROM or Internet download of the Loftware Software:

- Loftware End User License Agreement
- Loftware Third Party Terms and Conditions
- Loftware Software Services Support Agreement

Technical Support

Software licenses purchased directly from Loftware include the first year of Technical Support. This initial 12-month support period starts on the day the product is shipped and invoiced from Loftware's factory. When needed, support recipients during this period are eligible to receive unlimited telephone support, access to software upgrades and enhancements and speak with our Systems Analysts.

Premium Annual Support Contract

To ensure uninterrupted telephone support as well as access to the latest software upgrades and enhancements, make sure all your software licenses remain under a Loftware Support Contract. After your first year of ownership, you will be sent a notice to renew your support contract. Please refer to Loftware's website for additional information about this very important topic, or if you prefer, call Loftware's Customer Service Department for more information.

During the one-year Support Contract period, Contract Subscribers have access to the following services:

1. Unlimited Technical Support Incidents
2. Access to Loftware's Professional Services Group
3. Automatically eligible to download software upgrades and service packs from our website
4. Automatic e-mail notification when new versions of software become available
5. When necessary, access to senior Loftware technical support staff, via phone and e-mail
6. Guaranteed software license replacement for accidentally damaged or malfunctioning hardware keys

Before Calling Support

Loftware has highly trained technicians available to help you with your labeling system. Technical support calls are not accepted until all of the following Technical Support requirements are met:

1. Your product is registered. If you have not registered your software, you may do so at <http://loftware.com> or via fax by using the form included with your software.
2. There is a Support Contract in place that covers the specific license in question.



3. You have checked the user's guide(s) for your answer. If you do not have the User's Guides, both of the guides can be downloaded in PDF format from our web site or read on-line. User manuals are also on the Loftware CD.
4. You have checked the Loftware's Knowledge Base articles on our <http://loftware.com>. Hundreds of frequently asked questions and typical problems are documented there in easy to read articles.
5. If you suspect that your problem is hardware related, try to first determine if it is a problem with your computer, Network, or printer and contact the appropriate company. Loftware does not sell or service any hardware products.
6. Have your serial number and version number of the product you are using ready. These numbers can be obtained by accessing the Help | About menu of the label design mode.
7. Think about how you are going to efficiently explain the problem prior to speaking with a technician. The better the description, the quicker the solution and/or resolution to your problem.
8. If this is a follow up call to a previous incident, please have the incident number ready.

Phone 603-766-3630 x402

Fax 603-766-3635

E-mail support@loftware.com



About the Loftware Connector for SAP Applications

The Loftware Connector for SAP Applications takes ERP system label printing to a new level, driving a seamless flow of supply chain and manufacturing operations. The Loftware Connector for SAP Applications supports SAP label printing via

- External Output Management System (BC/XOM XMI) Call
- RFC Listening (Call Function, Destination)
- IDoc via ALE

The Loftware Connector for SAP Applications acts as an Output Management System (OMS) in SAP. It receives a file and sends it to the Loftware Print Server, which in turn sends the file/label to a printer. Status and issue can be managed in Loftware or sent back to SAP.

The Loftware Print Server is used as a design tool to create the label templates that will be populated with data from a given RDI from SAP.

- Based on fixed field list from SAP
- Loftware will handle standard SAP RDI output
- Fully integrates with SAP spool

For more details on integrating SAP with an OMS, see [Integrating the Spool System into an External Output Management System](#) on the SAP help system, help.sap.com.

Loftware Connector for SAP Applications Print Process

A print job is initiated in SAP through an automatic or manual process. SAP will create an RDI file and send it to the Loftware Connector for SAP Applications for printing. The following is the general process of label printing using the Loftware Connector for SAP Applications.

1. SAP application determines the device, SAP form and Loftware form.
2. SAP Form tool generates output.
3. Loftware Connector for SAP Applications receives the print request.



4. Loftware Connector for SAP Applications translates SAP print request to final layout.
5. The Loftware Print Server sends the label to printer.
6. Loftware Connector for SAP Applications returns status to SAP.



Install Overview

The Loftware Connector for SAP Installation program installs the following components:

- Loftware Connector for SAP Applications Server
- Loftware Enterprise Update
- Loftware Connector for SAP Applications Configuration User Interface

Loftware Connector for SAP Server

The Loftware Connector for SAP Applications Server component provides the integration between your SAP system and the Loftware Print Server.

Loftware Enterprise Update

Loftware Enterprise Update component synchronizes the data between the Loftware Connector for SAP Applications Server's database and the Loftware Print Server.

Note: The Loftware Connector for SAP Server requires Loftware Enterprise Update. Remote Installations of the Loftware Print Server used with the Loftware Connector for SAP Applications also require Loftware Enterprise Update.

Loftware Connector for SAP Configuration

The Loftware Connector for SAP Applications Configuration component provides a user interface for updating the Loftware Connector for SAP Server.



Installation Requirements

The following are required before installing the Loftware Connector for SAP Applications.

Operating System

Loftware Connector for SAP Applications

The Loftware Connector for SAP Applications is supported on the following operating systems.

- Microsoft Windows Server 2003 SP2 (32-bit)
- Microsoft Windows Server 2008 R1 (32-bit)
- Microsoft Windows Server 2008 R2 (64-bit)

Note: The Loftware Connector for SAP Applications and the Loftware Print Server are 32-bit applications.

The following operating system features must be installed and configured according to the instructions in this guide.

- Microsoft Windows Internet Information Services (IIS)
 - ASP .NET (Version 2.0)

Note: You may need to manually register ASP .NET version 2.0 with IIS on Windows Server 2003. See [Microsoft .NET Framework](#) for instructions.

- Microsoft .NET 3.5 Framework

Important! You must apply the latest critical updates to your operating system, IIS, and the .NET Framework through Windows Update.

Command Line Interpreter

The Loftware Connector for SAP Applications Command Line (CLI) is supported on the following operating systems.



- Microsoft Windows Server 2003 SP2 (32-bit)
- Microsoft Windows Server 2008 R1 (32-bit)
- Microsoft Windows Server 2008 R2 (64-bit)
- AIX 5.3 or 6.1
- Solaris 10
- HPUX 11.0

Browser

- Microsoft Internet Explorer Version 8.0 or later with **Active Scripting** enabled.
- Mozilla Firefox Version 3.6.8 or later with **JavaScript** enabled.

See [Enable Scripting in Client Browsers](#) for instructions on activating scripting in your browser.

Software

- Installation of the Loftware Print Server Version 9.8 and above
 - Loftware Enterprise Update License

Third Party

- A server license file. Please contact Loftware Sales or Professional Service Group for information on obtaining a license.

Note: When the Loftware Connector for SAP Applications is installed on a failover cluster, a license file is required on each node of the cluster.

- A configured SAP environment.
 - Registration of the Loftware Connector for SAP through SAP Solution Manager.

The Loftware Connector for SAP Applications Command Line (CLI) requires the following:

- Java Runtime (JRE) Version 1.6

Microsoft Internet Information Services (IIS)

The Loftware Connector for SAP Applications requires Microsoft Internet Information Services (IIS). IIS is configured differently depending on the operating system.

Adding IIS in Windows Server 2003 (32 - Bit)

1. Open the Control Panel, and select **Add or Remove Programs**.
2. Select **Add/Remove Windows Components**.
3. Select **Application Server**, and click **Details**.
4. Select **ASP.NET** and **Internet Information Services (IIS)**, and click **OK**
5. Click **Next**, and follow the instructions on the installation windows.

Adding IIS to Windows Server 2008

1. Open the Control Panel, and select **Programs**, and then **Programs and Features**.
2. Select **Turn Window features on or off**. The **Server Manager** opens.
3. Select the **Roles** page, and click **Add Roles**. The **Add Roles Wizard** opens.
4. Click **Next** if necessary to open the **Select Server Roles** page.
5. Select **Web Server (IIS)**, and click **Add Required Features** if the **Add features required for Web Server (IIS)** window appears.
6. Click **Next**, and select **Role Services**.
7. Select the following from the **Application Development** section, and click **Add Required Features** if the **Add features required for Web Server (IIS)** window appears:
 - ASP.NET
 - .NET Extensibility



- ISAPI Extensions
 - ISAPI Filters
8. Select and expand **Security**, and then select **Windows Authentication**.
 9. Select and expand **Management Tools**, and then expand **IIS 6 Management Compatibility**.
 10. Select **IIS 6 Metabase Compatibility**.
 11. Click **Next**, and then click **Install**.

Microsoft .NET Framework

The Loftware Connector for SAP Applications installation programs installs the .NET Framework in most cases. However, if you installed the .NET Framework before adding IIS, you must manually register the .NET Framework with IIS. In Windows Server 2008 R2, you must add the .NET Framework 3.5.1 Features.

Manually registering the .NET Framework 2.0 in Windows Server 2003 (32 Bit)

You may need to perform this step if you install the Microsoft .NET Framework after installing Internet Information Services.

1. Open a command window with administrative privileges. Right-click **Command Prompt** and select **Run as administrator**.
2. Navigate to the .NET Framework windows folder, and enter the `aspnet_regiis.exe -i` command. For example:

```
C:\WINDOWS\Microsoft.NET\Framework\v2.0.50727\>aspnet_regiis.exe -i
```

Manually registering the .NET Framework in Windows Server 2008 (32 Bit)

1. Open a command window with administrative privileges. Right-click **Command Prompt** and select **Run as administrator**.
2. Navigate to the .NET Framework windows folder, and enter the `aspnet_regiis.exe -i` command. For example:

```
C:\WINDOWS\Microsoft.NET\Framework\v2.0.50727\>aspnet_regiis.exe -i
```



Adding .NET Framework in Windows Server 2008 (64 Bit)

1. Open the Control Panel, and select **Programs**, and then **Programs and Features**.
2. Select **Turn Window features on or off**. The **Server Manager** opens.
3. Select the **Features** page, and click **Add Features**. The **Add Features Wizard** opens.
4. Select .NET Framework 3.5.1 Features, and click **Add Required Features** if the **Add features required for .NET Framework 3.5.1 Features** window appears.

Note: One of the required features for the .NET Framework is the Web Server (IIS), which is also a requirement for the Loftware Connector for SAP.

SAP Connectivity and Security

In order to support the Loftware Connector for SAP XMI Callback feature, the user id created for access to SAP will need authorizations in SAP for certain function modules, function groups, and data dictionary objects.

Note for Professional Services or Expert Installers: The extent of the required authorizations will decrease as the project progresses from development through testing to production. Additionally, the SAP user id can ultimately be a background user (Communication User), although during development and testing it should have dialog access for debugging purposes. If desired, up to 3 concurrent users can be supported to improve performance on print request.

The Loftware Connector for SAP Applications connects to the SAP system as an RFC Client via the saprfc.ini file. The RFC Client connectivity will require the SAP BASIS group to provide the standard SAP connection information, typically accessible via the SAPGUI logon pad, and consisting of:

- SAP Connection Type
- SAP Application Server Name or IP Address
- SAP System Number
- Client No
- SAP User ID



- Password
- Language

Transaction Specific Details

For the specific SAP transactions as referenced below, the following SAP User authorizations will be necessary:

SAP Function Modules

Type	Name	Auth Data
RFC/BAPI	RFC_GET_FUNCTION_INTERFACE	RFC1
RFC/BAPI	RFC_GET_STRUCTURE_DEFINITION(_P) Or RFC_GET_UNICODE_STRUCTURE	RFC1 RFCH
RFC/BAPI	RFCPING	SYST
RFC/BAPI	RFC_SYSTEM_INFO	SRFC
RFC/BAPI	SXMI_LOGON	SXMI
RFC/BAPI	SXMI_LOGOFF	SXMI
RFC/BAPI	SXMI_XOM_JOBS_CALLBACK	SPOO
RFC/BAPI	SXMI_XOM_RMGS_QUERY	SPOO

Note: Additional authorizations for various function groups may also be necessary depending upon how the SAP security profiles are defined in the SAP system.



Deployment Scenarios

Your computer system or network configuration may require a custom deployment of the Loftware Connector for SAP Applications. The following are possible deployment scenarios.

Note: Some of these scenarios may require manual changes to configuration files.

Note: The Server component requires the Enterprise Update component. Enterprise Update will always be installed with the Server.

Non-Clustered Deployments

This section describes the supported configurations of the Loftware Print Server and the Loftware Connector for SAP Applications on single non-clustered servers.

Connector with Single Loftware Print Server

In this configuration all components of the Loftware Print Server and the Loftware Connector for SAP Applications are installed on a single server or workstation.

Component	Server
The Loftware Print Server	x
Connector Server	x
Enterprise Update	x
Configuration User Interface	x



Connector with a Single Loftware Print Server and a Remote Configuration User Interface

In this configuration the Loftware Print Server, the Loftware Connector for SAP Applications Server and Loftware Enterprise Update are installed on a single server or workstation. The Configuration User Interface is installed on a separate remote system.

Component	Server	Remote System
The Loftware Print Server	x	
Connector Server	x	
Enterprise Update	x	
Configuration User Interface		x

Note: The Configuration User Interface is limited in its diagnostic reporting by security restrictions. The user on the remote system must have access to the Loftware Connector for SAP Applications server to view diagnostic information.

Connector with Multiple Loftware Print Servers

In this configuration all components of the Loftware Print Server and the Loftware Connector for SAP Applications are installed on one server. There are one or more additional servers that have both the Loftware Print Server and Loftware Enterprise Update installed.

Component	Server	Server	Server
The Loftware Print Server	x	x	x
Connector Server	x		
Enterprise Update	x	x	x
Configuration User Interface	x		

Note: The Configuration User Interface is limited in its diagnostic reporting by security restrictions. The user on the remote system must have access to the Loftware Connector for SAP Applications server to view diagnostic information.

The Configuration User Interface is not able to report status or version info on multiple LPS systems.

Connector with Multiple Loftware Print Servers and a Remote Configuration User Interface

In this configuration the Loftware Print Server is installed on two separate servers. One of those servers has the Connector Server and Loftware Enterprise Update installed. The second LPS server has Loftware Enterprise Update installed. A remote system has the Configuration User Interface installed.

Component	Server	Server	Remote System
The Loftware Print Server	x	x	
Connector Server	x		
Enterprise Update	x	x	
Configuration User Interface			x

Note: The Configuration User Interface is limited in its diagnostic reporting by security restrictions. The user on the remote system must have access to the Loftware Connector for SAP Applications server to view diagnostic information.

The Configuration User Interface is not able to report status or version info on multiple LPS systems.

Clustered Deployments

Connector with Single Clustered Loftware Print Server

In this configuration the Loftware Print Server and all components of the Loftware Connector for SAP Applications are installed on each node of a failover cluster.

Component	Node	Node
The Loftware Print Server	x	x
Connector Server	x	x
Enterprise Update	x	x
Configuration User Interface	x	x



Note: The Configuration User Interface is limited in its diagnostic reporting to the owner node for certain information.

Connector with Single Clustered Loftware Print Server and Remote Configuration User Interface

In this configuration the Loftware Print Server and the Loftware Connector for SAP ApplicationsServer are installed on a failover cluster, and the Configuration User Interface is installed on a remote server.

Component	Node	Node	Remote System
The Loftware Print Server	x	x	
Connector Server	x	x	
Enterprise Update	x	x	
Configuration User Interface			x

Note: The Configuration User Interface is limited in its diagnostic reporting by security restrictions. The user on the remote system must have access to the Loftware Connector for SAP Applications server to view diagnostic information.

The Configuration User Interface can report version information for only Provdva and Rudy.

Connector with Multiple Clustered Loftware Print Servers

In this configuration Loftware Print Servers are installed on separate failover clusters. The Loftware Connector for SAP Applications is installed on one of the clusters.

Component	Cluster 1		Cluster 2	
	Node	Node	Node	Node
The Loftware Print Server	x	x	x	x
Connector Server	x	x		
Enterprise Update	x	x	x	x
Configuration User Interface	x	x		

Connector with Multiple Clustered Loftware Print Servers and Remote Configuration User Interface

In this configuration Loftware Print Servers are installed on separate failover clusters. The Loftware Connector for SAP Applications is installed on one of the clusters, and the Configuration User Interface is installed on a remote server.

Component	Cluster 1		Cluster 2		Remote
	Node	Node	Node	Node	
The Loftware Print Server	x	x	x	x	
Connector Server	x	x			
Enterprise Update	x	x	x	x	
Configuration User Interface					x



Install the Loftware Connector for SAP Applications

The following are instruction for installing all the Loftware Connector for SAP Applications on a single server.

For information on the possible configurations of the Loftware Connector for SAP Applications see "[Deployment Scenarios](#)" on page 18 in this guide.

1. Verify that you have installed and configured the [requirements](#) for the Loftware Connector for SAP Applications.
2. Run **Setup** from the Loftware Connector for SAP Applications CD or download.
3. Select **Complete** from the **Setup Type** screen, and click **Next**.

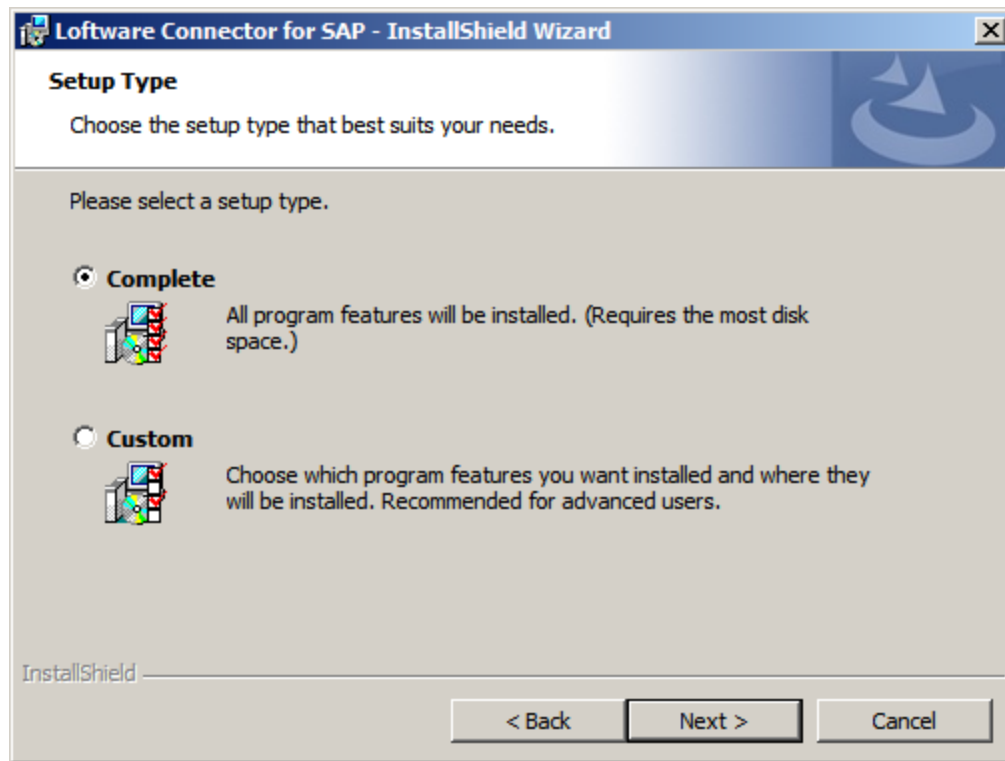

Figure 5.1: Software Connector for SAP Applications Installation Wizard Setup Type Screen

4. Follow the instructions in the installation wizard.

Note: The Software Connector for SAP Applications Installation program installs all the components needed using separate setup programs. You will click the **Install** and **Finish** buttons more than once each as the Software Connector for SAP Applications is installed.

Install Loftware Enterprise Update on a Remote Loftware Print Server System

If you are printing using multiple LPS systems, you must install Loftware Enterprise Update on all systems where additional LPS systems are installed.

Note: Loftware Enterprise Update runs as a service and updates the Loftware Connector for SAP Applications database with the LPS printer configuration.

For information on the possible configurations of the Loftware Connector for SAP Applications see "Deployment Scenarios" on page 18 in this guide.

1. Verify that you have installed and configured the [requirements](#) for the Loftware Connector for SAP Applications.
2. Run **Setup** from the Loftware Connector for SAP Applications CD or download.
3. Select **Custom** from the **Setup Type** screen, and click **Next**.
4. Select **This feature will not be available** next to the **Server** and **Configuration** components.

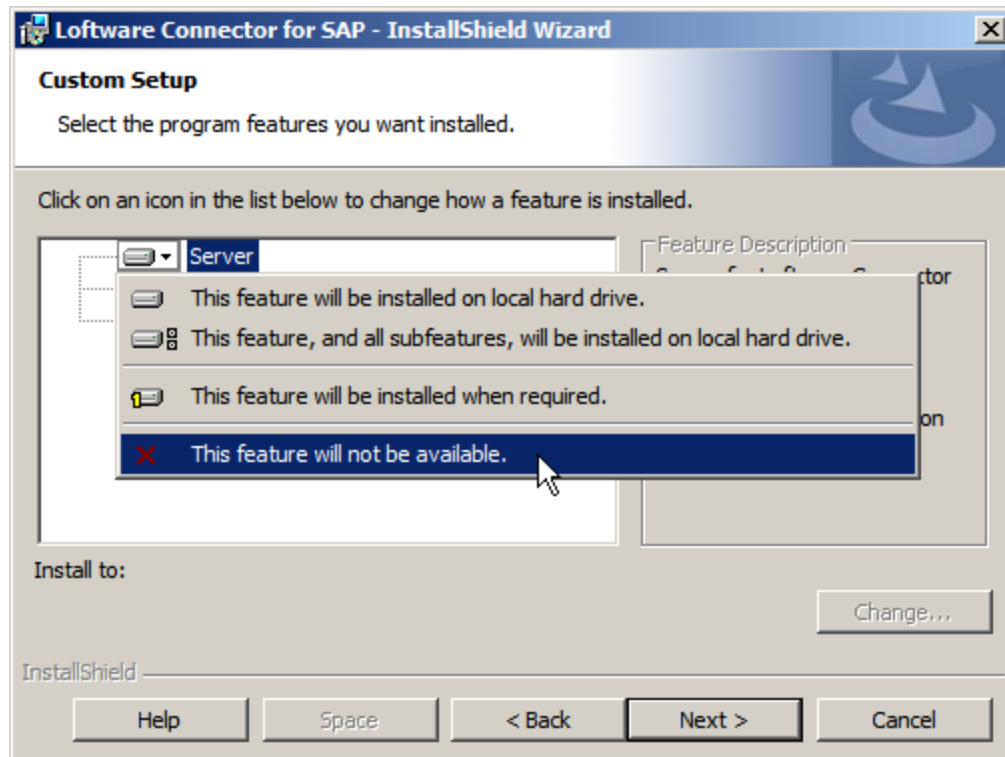

Figure 5.2: Loftware Connector for SAP Applications Installation Wizard Custom Setup

5. Click **Next**, and then click **Install**.
6. On the Installation Locations screen, in the **Remote Connector System** field, enter the UNC path to the location where the Loftware Connector for SAP Applications is installed, and click **Next**.

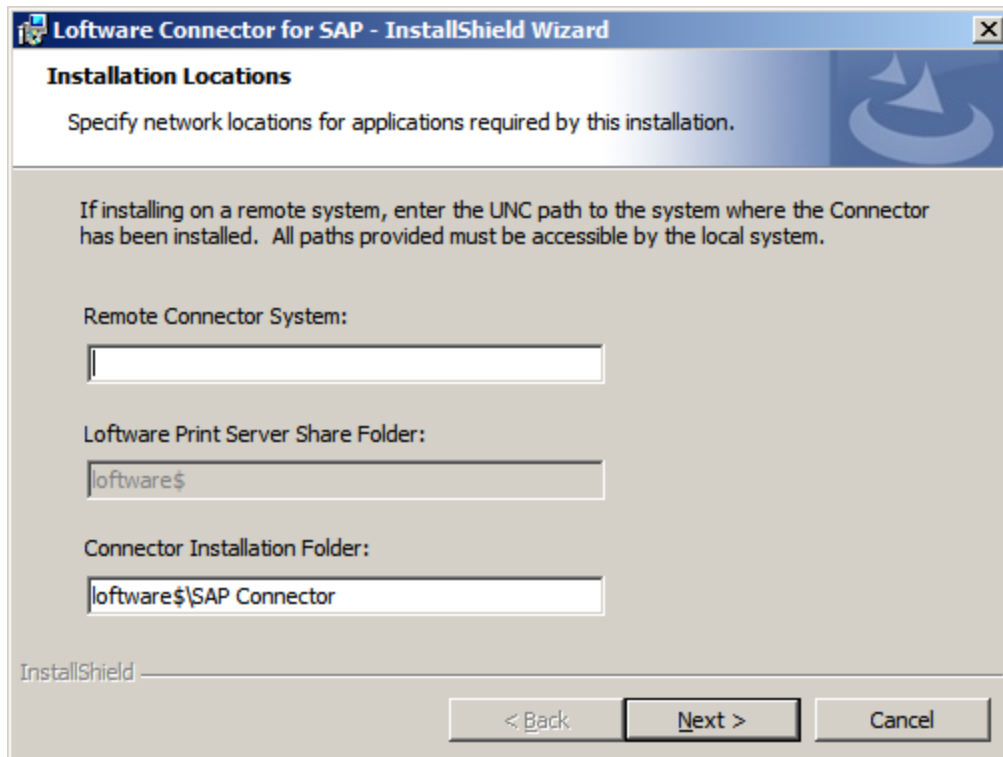

Figure 5.3: Loftware Connector for SAP Applications Installation Wizard Installation Locations

7. Follow the instructions in the installation wizard.
8. Start the Loftware Enterprise Update Service.



Change the Remote Connector System

In certain cases, you may find it necessary to change the Loftware Connector for SAP Applications system that Loftware Enterprise Update Service points toward.

1. Modify the LwEntUp.exe.config file.
2. Open Start | All Programs | Loftware Labeling | Datasources ODBC, Click **System DSN**, select **Provda**, and click **Remove**.
3. Open a command prompt, and add a new System DSN by entering the following command. Replace <NewLCfSAPHostName> with the UNC path to the new Loftware Connector for SAP Applications system.

```
odbcconf /a {CONFIGSYSDSN "Microsoft Access Driver (*.mdb)" "DSN=Provda|DBQ=\\<NewLCfSAPHostName>\loftware$\SAP  
Connector\Config\metadata\Provda.mdb"}
```

Install the Loftware Connector for SAP Applications Configuration User Interface on a Remote Server

In certain situations, it may be necessary to install the Loftware Connector for SAP Applications Configuration User Interface on a separate server.

For information on the possible configurations of the Loftware Connector for SAP Applications see "[Deployment Scenarios](#)" on page 18 in this guide.

1. Verify that you have installed and configured the [requirements](#) for the Loftware Connector for SAP Applications.
2. Run **Setup** from the Loftware Connector for SAP Applications CD or download.
3. Select **Custom** from the **Setup Type** screen, and click **Next**.
4. Select **This feature will not be available** next to the **Server** and **Enterprise Update** components.

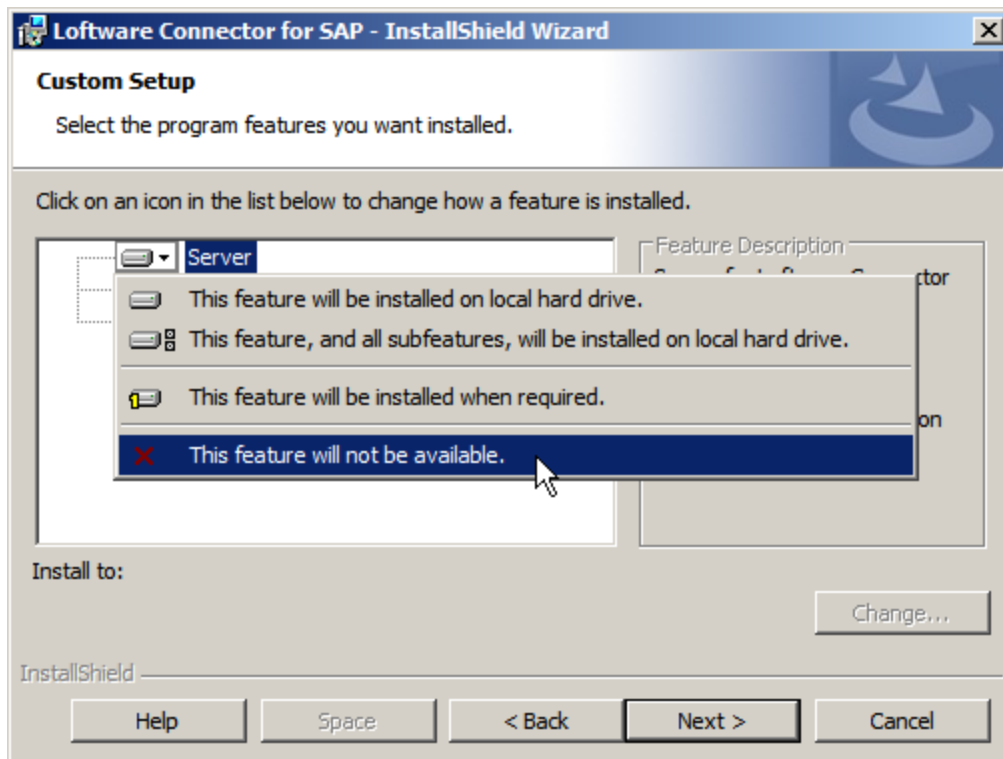

Figure 5.4: Loftware Connector for SAP Applications Installation Wizard Custom Setup

5. Click **Next**, and then click **Install**.
6. On the Installation Locations screen, in the **Remote Connector System** field, enter the UNC path to the location where the Loftware Connector for SAP Applications is installed, and click **Next**.

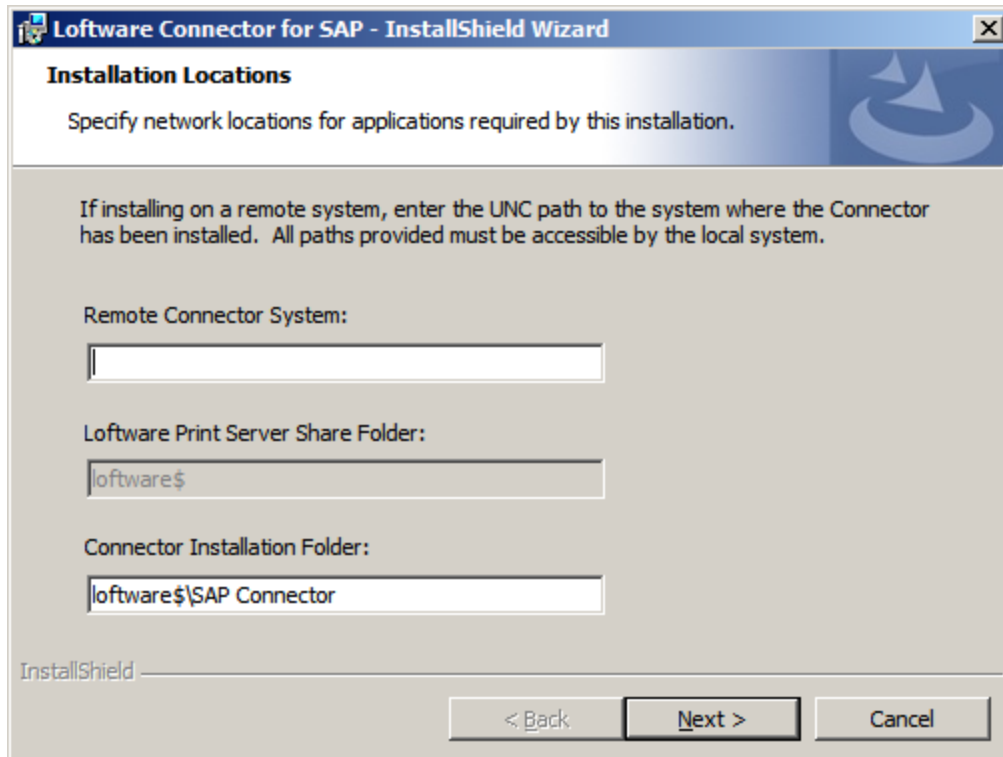

Figure 5.5: Software Connector for SAP Applications Installation Wizard Installation Locations

7. Follow the instructions in the installation wizard.

Register your Loftware Connector for SAP

The following are the steps to register Loftware Connector for SAP Applications product information to your SAP System Landscape Directory (SLD) using Solution Manager.

1. Get the following information for the SLD server, and log on to the System Landscape Directory.



Note: The user logged in must have an LcrInstanceWriterLD role.

Host	
Port	
User	
Password	

2. Open the `LoftwareConnector.properties` text file in a text editor such as Notepad. By default this is installed to `C:\Program Files (x86)\Loftware Labeling\SAP Connector\SolutionManager`.
 - Fill in a value for `ComputerName`, at the bottom of this file, replacing `PleaseFillIn`. DO NOT change anything else in this file. Save and close the file.

```
#
# IV/ Enter the name of the host where your system is installed.
# The name specified here needs to be substituted at run time.
# The value must be entered in lower case without any network domain.
#
ComputerName = PleaseFillIn
#
# V/ Check your data in SLD after registration.
# Go to page "Content Maintenance" or "CIM Instances". The central object to
# check in SLD is of class "Application System" (= "SAP_ApplicationSystem").
# Check the associations of this instance, there must be five other instances
# associated:
# 1. A Computer System (SAP_ComputerSystem)
# 2. An Installed Product (SAP_InstalledProduct)
# 3. An Installed Software Component (SAP_InstalledSoftwareComponent)
# 4. Two times the same Supplied Elements (SAP_SuppliedElements)
#
```

3. Run the following java command from SAP, replacing the placeholder text as necessary:

```
java -cp . com/sap/lcr/tools/xmlTools/ThirdPartySystemXMLGenerator
<Source path> <Parameters file> <Template file> <Result path> <Result XML file>
```



For Example

```
java -cp . com/sap/lcr/tools/xmlTools/ThirdPartySystemXMLGenerator .  
LoftwareConnector.properties ThirdPartySystem.template . LoftwareConnector.xml.
```

This java command creates an xml file named LoftwareConnector.xml.

4. Run the following java command from SAP, replacing the placeholder text as necessary with the information from Step 1:

```
java -cp . example/Test <SLD host> <http_port> <user> <password> LoftwareConnector.xml
```

For Example

```
java -cp . example/Test your.solman.com 80 youruser yourpass LoftwareConnector.xml
```

Your installation of the Loftware Connector for SAP will be registered in your SAP Solution Manager Directory.

Upgrading from the Loftware Connector for SAP version 1.5.x to the Loftware Connector for SAP Applications version 2.0

An upgrade to the Loftware Connector for SAP Applications version 2.0 from version 1.5.x must be performed by Loftware Professional Services.

The Loftware Connector for SAP Applications requires the Loftware Print Server Version 9.8 or later.



Install the Loftware Connector for SAP Applications on a Failover Cluster

The installation wizard for the Loftware Connector for SAP Applications recognizes when the Loftware Print Server is being installed on a failover cluster, and will configure the Loftware Connector for SAP Applications on the cluster.

Cluster Installation Requirements

- The Loftware Print Server version 9.8 must be installed and configured on the cluster as described in the *Loftware Print Server and Label Manager Installation Guide*.
- Each node on the cluster must be configured with the features described in "[Installation Requirements](#)" on page 12 in this document.

Note: You will need a license file on each node of the cluster.

Configuration Files

Certain configuration file changes must be performed on each node of the cluster. These include the following files.

- NLINK Configuration.XML
- LwEntUp.exe.config
- Web.config

Important!When you make changes to web.config you must make the changes on each node of the cluster. Restart IIS on each node after making changes to the web.config file.

On the Cluster Shared Folder

The following folders are created on the shared storage of the cluster.

SAP Connector\Config



- saprfc.ini

SAP Connector\Config\Metadata

- Loftware Label Printing.nlk
- Provda.mdb

SAP Connector\LCfSAPDrop

Install on a Cluster

Determine the Owner of the Quorum

Follow the instructions in *Loftware Print Server and Label Manager Installation Guide* for determining the owner of the quorum.

Install on Node 1

1. Run **Setup** from the Loftware Connector for SAP Applications CD or download.
2. Follow the instructions in the installation wizard.

Note: The Loftware Connector for SAP Applications Installation program installs all the components needed using separate setup programs. You will click the **Install** and **Finish** buttons several times as the Loftware Connector for SAP Applications is installed.

Install on Node 2

1. Run **Setup** from the Loftware Connector for SAP Applications CD or download.
2. Follow the instructions in the installation wizard.

Cluster Server Error

If a failover occurs while you are editing data in the SAP Configuration UI, one of the following runtime errors is returned:



- "An application error occurred on the server. The current custom error settings for this application prevent the details of the application from being viewed remotely (for security reasons)..."
The error message then details how to create a <customErrors> tag in the web.config file.
- "Validation of viewstate MAC failed... An unhandled exception occurred during execution of the current web request."
The message then details compiling in debug mode.

Workaround

The error occurs because session data is not currently being replicated across all nodes of the cluster. The workaround is to return to the **Edit Rules** page (or previous page). This will cause you to lose any work done just before the failover on the cluster occurred.



Post Installation

After installing the Loftware Connector for SAP Applications, please note the default file paths in the following table.

Path Name	Default Path for Windows Server 2003	Default Path for Windows Server 2008
Installation	C:\Program Files\Loftware Labeling\SAP Connector	C:\Program Files (x86)\Loftware Labeling\SAP Connector
Log/trace file	C:\Documents and Settings\All Users\Application Data\Loftware Inc\Labeling\SAP Connector\Logs	C:\Program Data\Loftware Inc\Labeling\SAP Connector\Logs
Joblog file	C:\Program Files\Loftware Labeling\WDDrop\Printed	C:\Program Files (x86)\Loftware Labeling\WDDrop\Printed
Configuration file	C:\Program Files\Loftware Labeling\SAP Connector\config\NLink Configuration.xml	C:\Program Files (x86)\Loftware Labeling\SAP Connector\config\NLink Configuration.xml

Note: In certain cases the Loftware Connector for SAP may be installed to Program Files (x86) instead of Program Files. The installation location is determined by Windows.

Activating the Server License

Copy the server license to the Loftware Connector for SAP Applications installation folder. By default, C:\Program Files (x86)\Loftware Labeling\SAP Connector.

Enable Scripting in Client Browsers

If you will be accessing the Loftware Connector for SAP Applications Configuration and Diagnostics Interface from a browser on a computer other than the server, you must enable scripting on that computer's browser.



Internet Explorer

Note: You can enable scripting for the Configuration User Interface only, and leave scripting disabled in the Internet zone by adding the `http://localhost/sapcon` website to the **Trusted sites** zone.

1. On the **Tools** menu, click **Internet Options**, and then click the **Security** tab.
2. Click the **Internet** zone.
3. Click **Custom Level**.
4. In the **Security Settings – Internet Zone** dialog box, click **Enable for Active Scripting** in the **Scripting** section.
5. Click **Back** to return to the previous page, and then click **Refresh** to run scripts.

Firefox

1. On the **Tools** menu, click **Options**.
2. On the **Content** tab, click to select the **Enable JavaScript** check box.
3. Click **Go back one page** to return to the previous page, and then click **Reload current page** to run scripts.

Configuring the Connection

After installing the Loftware Connector for SAP Applications you must configure the connection to your SAP system. See [The Loftware Connector for SAP Applications BC-XOM Connection](#) for information on configuring your BC-XOM and RFC interfaces to SAP.

Configuring RDI

[RDI Interface Architecture](#)

Starting the Services

After configuring your connection to SAP be sure to start the following services on your server:



- Loftware Connector for SAP
- Loftware Enterprise Update
- Loftware Print Server

Software Enterprise Update

Software Enterprise Update (LwEntUp.exe) is the application that synchronizes the ProvDa data to the actual Software Print Server data.

LwEntUp.exe.config

The LwEntUp.exe.config file contains the application configuration settings for Software Enterprise Update.

If the LwEntUp service is upgraded, the existing LwEntUp.exe.config file is not overwritten. This preserves existing configuration; however, there may be some new config settings added to the existing config file.

Changes to this configuration file require a restart of the Software Enterprise Update Service.

Application Settings

The following are the application settings in the Software Enterprise Update configuration file. These settings are within the <appSettings> section of the configuration file.

Setting	Description	Default	Value	Required
LogDir	This is the directory where the LWEntUp activity log file will be written. <add key="LogDir" value="."/>	None		Yes
LogName	This is the file name of the LWEntUp activity log. <add key="LogName" value="LwEntUp.log"/>	None		Yes



Setting	Description	Default	Value	Required
LogLevel	<p>This is the detail level for the LwEntUp activity log. The specified level and all numerically lower levels will be written:</p> <pre><add key="LogLevel" value="5"/></pre>	5 (Info)	0. System Error* 1. Error 2. System Warning* 3. Warning 4. System Info* 5. Info 6. Debug * "System" levels are written to the System Event Log.	No
LogFileMaxSize	<p>The maximum size in bytes for the LwEntUp activity log. When this size is reached, all previous entries will be erased and the log will start over.</p> <pre><add key="LogFileMaxSize" value="250000" /></pre>	250000		Yes
RecurseLabelSubdirs	<p>This determines whether LwEntUp will search for changes in subdirectories of Labels Path.</p> <pre><add key="RecurseLabelSubdirs" value="1" ></pre>	1 (on)	0 (off) 1 (on)	No
ConnectionType	<p>This is the type of database connection to the ProvDa database.</p> <pre><add key="ConnectionType" value="odbc" /></pre>	None	odbc sqlserver	Yes



Setting	Description	Default	Value	Required
ConnectionString	<p>This is the DAO Connection string to connect to the Provda database. Only change if the configured DSN changes (non-standard).</p> <pre><add key="ConnectionString" value="DSN=Provda;" /></pre>	None	String	Yes
OverrideHostname	<p>If set, this value will be used as the ServerName for all related label files and printer entries in the ProvDa Database.</p> <p>When this is set on a Cluster server, set its value to the Virtual Hostname to prevent the use of the actual Node name as the Server name in the ProvDa Database. This is required for a clustered LPS environment.</p> <pre><add key="OverrideHostname" value="" /></pre>	The name of the server		No
OverrideIP	<p>This is similar to OverrideHostname. This entry, if set, will be used for the connection information within the ProvDa Database.</p> <p>When this is set on a Cluster server; set its value to the Virtual IP Address to prevent the use of the actual Node IP Address as the Server Connection info in the ProvDa Database. This setting is required for a clustered LPS environment.</p> <pre><add key="OverrideIP" value="" /></pre>	The IP address of the server	IP Address	No
CacheResetRequestDir	<p>This value must reflect the actual path to the provda_cache_reset_request_log.xml file used by the Loftware Connector for SAP Applications to pick up changes to the ProvDa data.</p> <p>In an upgrade scenario, this entry is NOT added to the file automatically and MUST be added manually to function properly.</p> <p>On a cluster, this value should be expressed using a UNC share.</p>	C:\Program Files (x86)\Loftware Labeling\SAP Connector	Path	Yes



Setting	Description	Default	Value	Required
	<pre><add key="CacheResetRequestDir" value="." /></pre>			
CacheResetRequestFileName	<p>This is the name of the provda cache reset request log file.</p> <p>This setting is only changed if the corresponding "NLINK Configuration.xml" file value changes.</p> <p>In an upgrade scenario, this entry is NOT added to the file automatically and MUST be added manually to function properly (use the default value listed above).</p> <pre><add key="CacheResetRequestFileName" value="provda_cache_reset_request_log.xml" /></pre>	provda_cache_reset_request_log.xml		
LwEntUpResynchRequestFileName	<p>This is the name of the LwEntUp resynch request log file.</p> <pre><add key="LwEntUpResynchRequestFileName" value="lwentup_resynch_request_log.xml" /></pre>	lwentup_resynch_request_log.xml		
ResynchOnDirChange	<p>This setting controls the depth of syncing between the default label folder and the Provda database. If a change is made to a sub folder of the default labeling folder, only the changed folder is synchronized with Provda.</p> <p>This setting can be added to the LwEntUp.exe.config file, and set to 1 to cause Loftware Enterprise Update to completely resynch after a change to a sub folder.</p> <p>Note: This setting does not appear in the LwEntUp.exe.config file by default.</p>	None	<p>0 (sync changed folders)</p> <p>1 (sync all folders)</p>	No



Setting	Description	Default	Value	Required
CacheResetRequestMaxEntries	<p>This is the maximum number of entries that can be written to the Provda cache reset request log before it drops previous entries, oldest first. This manages the size of the provda cache reset request log file, entries (<ResetRequest> nodes) that exceed this amount will be truncated.</p> <p>In an upgrade scenario, this entry is NOT added to the file automatically and MUST be added manually to reflect the number of <ResetRequest> entries to retain. Set this value to 1000.</p> <pre><add key="CacheResetRequestMaxEntries" value="1000"/></pre>	1000		Yes
LabelWatcherBufferSize	<p>This sets the buffer size in bytes for incoming Label file/folder changes. Do not change this value.</p> <p>In an upgrade scenario, this entry is NOT added to the file automatically and does not need to be added.</p> <pre><add key="LabelWatcherBufferSize" value="4096"/></pre>	4096		No



Example LwEntUp.exe.config file

```
<?xml version="1.0" encoding="utf-8" ?>
<configuration>
  <appSettings>
    <add key="LogDir" value="." />
    <add key="LogName" value="LwEntUp.log" />
    <add key="LogLevel" value="6" />
    <add key="LogFileMaxSize" value="250000" />
    <add key="RecurseLabelSubdirs" value="1" />
    <add key="ConnectionType" value="odbc" />
    <add key="ConnectionString" value="DSN=Provda;" />
    <add key="OverrideHostname" value="" />
    <add key="OverrideIP" value="" />
    <add key="CacheResetRequestDir" value="." />
    <add key="CacheResetRequestFileName" value="provda_cache_reset_request_log.xml" />
    <add key="LwEntUpResyncRequestFileName" value="lwentup_resynch_request_log.xml" />
    <add key="CacheResetRequestMaxEntries" value="1000" />
    <add key="LabelWatcherBufferSize" value="4096" />
  </appSettings>
</configuration>
```



The Loftware Connector for SAP Applications BC-XOM Connection

Loftware uses the Loftware Connector for SAP Applications Command Line module to communicate with the SAP spooler. In a print request, the Loftware Connector for SAP Applications translates the SAP RDI file to XML and sends it to the Loftware Print Server. The Loftware Print Server applies the appropriate label format and sends the job to the printer, and then sends the status back to SAP via the Loftware Connector for SAP Applications.

The following figure is an overview of the components and the communication among the components:

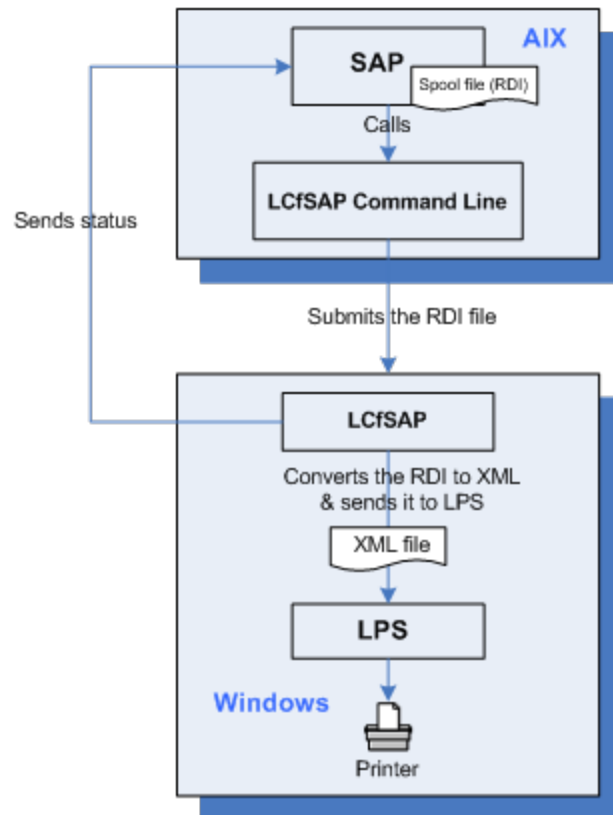

Figure 5.6: Loftware Connector for SAP Applications Components and Communication

This section describes steps for setting up the BC-XOM interface to Loftware Connector for SAP Applications. It assumes that all pre-requisites and the Loftware Connector for SAP Applications have been successfully installed. It also assumes that the user performing the install has working knowledge of the Loftware Connector for SAP Applications' components and SAP.



Some of the steps involve configuration within SAP by a system administrator on the SAP server and are included for information purposes only. Complete the following steps to configure your Loftware Connector for SAP Applications connection to your SAP system:

- [Configuring the Loftware Connector for SAP Applications](#)
- [Configuring the Loftware Connector for SAP Applications Command Line](#)
- [Configuring your SAP System](#)

RDI Interface Architecture

This section describes the general architecture of the Output Management System (OMS) component.

SAP

It is expected that the RDI passed to the Loftware Connector for SAP Applications will follow the standard SAP RDI format with Loftware specific Window-Element-Symname pairs being required for proper printing.

RDI has two components:

- The Header contains generic information about printer, device type, etc.
- Data contains the information to be printed. This component can contain information concerning multiple labels.

The data component is structured as follows:

Loftware

Loftware translates RDI to XML using the Loftware Print Server based schema.

Loftware provides the ability to use a fieldname list for design purposes via the defined List File (LST) format.

- The defined Window name for Loftware override information is "LABEL".
- The defined Element name for Loftware override information is "HEADER".

The following is a list of the Loftware-specific Window-Element-Symname RDI pairs and what they default to if omitted.



Note: If no default is given, then the value is considered 0 or blank.

LW_PRINTERNAME – Name (Printer Alias) of the printer to use

- Defaults to the Device Type found within the RDI header record structure

LW_JOBNAME – LPS Job Name for a give set of data

- Defaults to TDDATASET found within the RDI header record structure

LW_TRAY – Which paper tray from a laser printer to pull from

LW_QUANTITY – Number of unique labels to print for a set of data

- Defaults to TDCOPIES found within the RDI header record structure

LW_DUPLICATES – Number of duplicate labels to print for a set of data

LW_LABEL – The label format (lwl file) to use for a set of data

- Defaults to the Form Name found within the RDI header record structure

LW_PAGES – The number of pages to print with layouts

Configuring the Loftware Connector for SAP Applications

You must make modifications to the following files for BC-XOM integration.

NLINK configuration.xml

There are constants in the NLINK configuration.xml file that the Loftware Connector for SAP Applicationssystem must know about. These are described in ["Configure NLINK Configuration.xml" on page 48.](#)

Saprfc.ini

There are required entries in the Saprfc.ini file that the Loftware Connector for SAP Applications system must know about. These are described in ["Configure Saprfc.ini " on page 59.](#)

Provda

An entry to the LOMS must be set up in the table called `xom_callback_target_xref` in the Provda database. This table is used to associate the destinations configured in the NLINK Configuration.xml file to configured ROMS systems in SAP. This entry can be made using the Loftware Connector for SAP Applications [Configuration User Interface](#).

The table is structured as follows:

- `SapCallbackInstance` – The SAP instance selected as the Callback during the LOMS configuration.
- `SapRoms` – The ROMS name used during the ROMS configuration.
- `ExternalSystemNumber` – Specifies which of the `XmiCallbackx` settings to use from the “NLink Configuration.xml” file.

Configure NLINK Configuration.xml

NLINK Configuration.xml is the Environment Configuration for the Loftware Connector for SAP Applications. This file contains various configuration settings that must be updated if a non-standard installation is performed.

By default, NLINK Configuration.xml will be copied to:

```
...\Loftware Labeling\SAP Connector\Config
```

Note: The values for NLINK configuration settings are case-sensitive.

InterfaceLogFileAndPath Log File

This constant is the path and filename for the SAP_Interface log file. This log file tracks what the Loftware Connector for SAP Applications has processed. In a Cluster Installation, UNC path naming should be used.

Example of setting from Windows 2008 Server

```
<Constant Name="InterfaceLogFileAndPath">C:\ProgramData\Loftware Inc\Labeling\SAP Connector\Logs\sap_interface.log</Constant>
```

Note: When print requests are processed and the NLINK Configuration.xml DebugLevel is set to Production, after a while, the `sap_interface.log` file can get very large. You can delete the logfile once a day to keep it to a manageable size. A more convenient method is to append parameters when defining the `InterfaceLogFileAndPath` filename in the NLINK Configuration.xml file (for example, `sap_interface%y%j%H.log`).



When print requests are processed and the NLINK Configuration.xml DebugLevel is set to Production, after a while, the sap_interface.log file can get very large. You can delete the logfile once a day to keep it to a manageable size. A more convenient method is to append parameters when defining the InterfaceLogFileAndPath filename. Depending on the parameters, new logfiles are created daily, hourly, etc. For example:

Example of setting from Windows XP

```
<Constant Name="InterfaceLogFileAndPath">C:\Program Files\Loftware Labeling\SAP\logs\sap_interface%y%j%H.log</Constant>
```

In this example, the 2-digit year (%y), the day of year as decimal number (%j), and the hour in 24-hour format (%H) are added to sap_interface, for example, sap_interface0800510.log.

The following table describes the parameters that can be used:

Parameter	Definition
%a	Abbreviated weekday name
%A	Full weekday name
%b	Abbreviated month name
%B	Full month name
%c	Date and time representation appropriate for locale
%d	Day of month as decimal number (01-31)
%G	Gives filename a unique id
%H	Hour in 24-hour format (00-23)
%I	Hour in 12-hour format (01-12)
%j	Day of year as decimal number (001-366)
%m	Month as decimal number (01-12)



Parameter	Definition
%M	Minute as decimal number (00-59)
%p	Current locale's A.M./P.M. indicator for 12-hour clock
%S	Second as decimal number (00-59)
%U	Week of year as decimal number, with Sunday as first day of week (00-3)
%w	Weekday as decimal number (0-6; Sunday is 0)
%W	Week of year as decimal number, with Monday as first day of week (00 53)
%x	Date representation for current locale
%X	Time representation for current locale
%y	Year without century, as decimal number (00 99)
%Y	Year with century, as decimal number
%z, %Z	Time-zone name or abbreviation; no characters if time zone is unknown

ReadPrudyOnDemand

```
<!-- ReadPrudyOnDemand: TRUE = Will check cache first, then Rudy DB FALSE = Will read in all Rudy entries at startup/cache reset -->  
<Constant Name="ReadPrudyOnDemand">TRUE</Constant>
```

PassThroughAllowed

```
<!-- PassThroughAllowed: Leave this true if you intend to have Rule Assignments of DEFAULT-DEFAULT-DEFAULT -->  
<Constant Name="PassThroughAllowed">TRUE</Constant>
```



IsPrudyInstalled

```
<!-- IsPrudyInstalled: Always leave this TRUE -->  
<Constant Name="IsPrudyInstalled">TRUE</Constant>
```

Default Print Job Constants

```
<Constant Name="DefaultJobName">LoftwareConnectorForSAP</Constant>  
<Constant Name="DefaultQuantity">1</Constant>  
<Constant Name="DefaultDuplicates">0</Constant>  
<Constant Name="DefaultPages"/>  
<Constant Name="DefaultPrinterNumber">1</Constant>  
<Constant Name="DefaultPrinterName"/>  
<Constant Name="DefaultTray"/>  
<Constant Name="DefaultServerName">loftware</Constant>  
<Constant Name="SendEmailOnError">FALSE</Constant>  
<Constant Name="SendEmailTo"/>  
  
<!-- SendPrintRequestViaFile: Leave this as FALSE -->  
<Constant Name="SendPrintRequestViaFile">FALSE</Constant>  
<Constant Name="PrintRequestDropPath">\</Constant>  
  
<Constant Name="SendPrintRequestViaSocket">TRUE</Constant>  
  
<Constant Name="RecordTimestamps">FALSE</Constant>  
<Constant Name="SendTimestampReport">FALSE</Constant>  
<Constant Name="SendTimestampReportTo"/>
```

Listener Constants

Constant	Description	Settings
LoftwareListener[x]Destination	A type R RFC Server	R DEST entry from the saprfc.ini file
LoftwareListenerXNumConnections	Controls the number of simultaneous RFC connections.	Set to a number
LoftwareIDocListenerDestination	A type R RFC Server.	R DEST entry from the saprfc.ini file Set to blank to disable this IDoc system
LoftwareIDocListenerNumconnections	See LoftwareIDocListenerDestination entry to disable the IDoc system	Set to 1 or more



```
<Constant Name="LoftwareListener1Destination">LOFTWARE1</Constant>
<Constant Name="LoftwareListener2Destination" />
<Constant Name="LoftwareListener3Destination" />

<!-- LoftwareListenerXNumConnections: Set to 0 to disable Listener 1 -->
<Constant Name="LoftwareListener1NumConnections">1</Constant>
<Constant Name="LoftwareListener2NumConnections">0</Constant>
<Constant Name="LoftwareListener3NumConnections">0</Constant>
<Constant Name="LoftwareIDocListenerDestination" />

<!-- LoftwareIDocListenerNumConnections: Set to 1 or more to enable IDocs -->
<Constant Name="LoftwareIDocListenerNumConnections">0</Constant>
```

File Drop Testing Constants

Constant	Description	Settings
RdiManualFileDropPath	System path to receive .rdi file trigger print requests	C:\Program Files\Loftware Labeling\SAP Connector\LCfSAPDrop
Rdi- ManualFileDropFilename	Filename (can include wildcards) for .rdi file trigger print requests	*.rdi
XmlTestTriggerFilePath	System file path to receive .xml file trigger print requests	C:\Program Files\Loftware Labeling\SAP Connector\LCfSAPDrop
XmlTestTriggerfileName	Filename (can include wildcards) for .xml file trigger print requests	*.xml

```
<!-- RDI drop location for testing RDI parsing with the connector -->
<Constant Name="RdiManualFileDropPath">C:\Program Files (x86)\Loftware Labeling\SAP Connector\LCfSAPDrop</Constant>
<Constant Name="RdiManualFileDropFilename">*.rdi</Constant>

<!-- XML drop location for testing rules with the connector -->
<Constant Name="XmlTestTriggerFilePath">C:\Program Files (x86)\Loftware Labeling\SAP Connector\LCfSAPDrop</Constant>
<Constant Name="XmlTestTriggerFileName">*.xml</Constant>
```



Log File Constants

Constant	Description	Settings
EmailNotificationReturnAddress	The "from" address for any emails	Not Set
ProvdaOdbcDataSourceName	Name of the ODBC entry for Provda	provda
CacheResetRequestPath	System file path for the cache reset request log files	C:\Program Files\Loftware Labeling\SAP Connector
ProvdaCacheResetRequestFileName	Filename for the Provda cache reset request log	provda_cache_reset_request_log.xml
RudyCacheResetRequestFileName	Filename for the rudy cache reset request log	rudy_cache_reset_request_log.xml

Debug Constants

Constant	Description	Settings
CreateDumpFile	Indicate whether to write to the dump file	0 = no 1 = yes
DebugLevel	Set debug level	0 = debug 1 = production

Contact Constants

Constant	Description	Settings
EmailAddressOfNlinkAdministrator	Email address to receive automatically generated NLINK emails (usually only errors); set to blank to disable automatic emails	
EmailErrorLevel	Indicate when to send event log messages to administrator	0=info 1=warning 2=error



NLINK Configuration.xml Settings for BC-XOM Integration

The following settings are included in the NLINK Configuration.xml file for BC-XOM integration. These settings are required for every external SAP system that the LCfSAP system must know about. Currently, as with the RFC integration, the LCfSAP system can configure up to three different SAP instances.

The [x] in each setting by default can be 1, 2, or 3.

Setting	Description
Xmi-Callback[x]Destination	Reference to the DEST specified in the saprfc.ini file
XmiCallback[x]Client	Client number for the LCfSAP system to use when connecting back to the SAP instance
XmiCallback[x]UserId	User ID for the LCfSAP system to use when connecting back to the SAP instance
XmiCallback[x]Password	Encrypted password for the User ID specified above. Junot Systems, Inc. has a utility for encrypting the password. Refer to the NLINK Password.exe topic in this guide for more information (page See "NLINKPassword.exe").
XmiCallback[x]Language	Language for the LCfSAP system to use and expect when logging into the SAP instance with the above User ID

For example

```
<Constant Name="XmiCallback1Destination">SAP46</Constant>
<Constant Name="XmiCallback1Client">800</Constant>
<Constant Name="XmiCallback1UserId">LOFTWARE</Constant>
<Constant Name="XmiCallback1Password">mJH1SPRG9ErFJA==</Constant>
<Constant Name="XmiCallback1Language">E</Constant>
<Constant Name="XmiCallback2Destination" />
<Constant Name="XmiCallback2Client" />
<Constant Name="XmiCallback2UserId" />
<Constant Name="XmiCallback2Password" />
<Constant Name="XmiCallback2Language">E</Constant>
<Constant Name="XmiCallback3Destination" />
<Constant Name="XmiCallback3Client" />
<Constant Name="XmiCallback3UserId" />
<Constant Name="XmiCallback3Password" />
<Constant Name="XmiCallback3Language">E</Constant>
```



Command Line Interface Constants

```
<!-- The 'init' command issued via the CLI will reference the "LoftwareWebServicePortSynch" setting - remember to add the
'/synch/' URI to the command line parameter -->
<Constant Name="LoftwareWebServicePortSynch">8081</Constant>

<!-- The 'submit' command issued via the CLI will reference the "LoftwareWebServicePortAsynch" setting. -->
<Constant Name="LoftwareWebServicePortAsynch">8080</Constant>
```

Testing settings

The following entries are included for the LoadTest interface used during testing. They are needed in production mode only so that errors do not occur if the xml settings are not found. The values in the XML file are not set.

```
<Constant Name="LCfSAPTestMode"/>
<Constant Name="LCfSAPTestOdbcDataSourceName"/>
<Constant Name="LCfSAPTestDatabaseUserId"/>
<Constant Name="LCfSAPTestDatabasePassword" EditMask="PASS"/>
```

LoftwareBulkJobStatusLimit

If you change this value, you must also change the corresponding value for the Loftware Print Server. The Loftware Print Server setting is stored in the Windows registry. Loftware recommends leaving this setting at the default.

```
<Constant Name="LoftwareBulkJobStatusLimit">100</Constant>
```

Constant	Description	Setting
RDIParseASegment	Set to TRUE to parse Mail Application Object	FALSE
RDIParseRSegment	Set to TRUE to parse Mail Recipient	FALSE
RDIParseMSegment	Set to TRUE to parse Mail Sender	FALSE
RDIParseSSegment	Set to TRUE to parse Sort	FALSE
RDIParsePSegment	Set to TRUE to parse Archive Parameter	FALSE



Constant	Description	Setting
RDIParseISegment	Set to TRUE to parse Archive Index	FALSE
RDIParseCSegment		FALSE
RdiNewLabelOnRepeatElement		FALSE

Example NLINK Configuration.xml file

```
<?xml version="1.0" encoding="UTF-8"?>
<!--NLINK constants-->
<Constants version="2.0.2.5">
  <CurrentEnvironment>Production</CurrentEnvironment>
  <DefaultEnvironment>
    <Constant Name="InterfaceLogFileAndPath">C:\ProgramData\Loftware Inc\Labeling\SAP Connector\Logs\sap_
interface.log</Constant>
    <!-- ReadPrudyOnDemand: TRUE = Will check cache first, then Rudy DB FALSE = Will read in all Rudy entries at
startup/cache reset -->
    <Constant Name="ReadPrudyOnDemand">TRUE</Constant>
    <!-- PassThroughAllowed: Leave this true if you intend to have Rule Assignments of DEFAULT-DEFAULT-DEFAULT -->
    <Constant Name="PassThroughAllowed">TRUE</Constant>
    <!-- IsPrudyInstalled: Always leave this TRUE -->
    <Constant Name="IsPrudyInstalled">TRUE</Constant>
    <Constant Name="DefaultJobName">LoftwareConnectorForSAP</Constant>
    <Constant Name="DefaultQuantity">1</Constant>
    <Constant Name="DefaultDuplicates">0</Constant>
    <Constant Name="DefaultPages"/>
    <Constant Name="DefaultPrinterNumber">1</Constant>
    <Constant Name="DefaultPrinterName"/>
    <Constant Name="DefaultTray"/>
    <Constant Name="DefaultServerName">loftware</Constant>
    <Constant Name="SendEmailOnError">FALSE</Constant>
    <Constant Name="SendEmailTo"/>
    <!-- SendPrintRequestViaFile: Leave this as FALSE -->
    <Constant Name="SendPrintRequestViaFile">FALSE</Constant>
    <Constant Name="PrintRequestDropPath">\</Constant>
```



```
<Constant Name="SendPrintRequestViaSocket">TRUE</Constant>
<Constant Name="RecordTimestamps">FALSE</Constant>
<Constant Name="SendTimestampReport">FALSE</Constant>
<Constant Name="SendTimestampReportTo"/>
<Constant Name="LoftwareListener1Destination">LOFTWARE1</Constant>
<Constant Name="LoftwareListener2Destination"></Constant>
<Constant Name="LoftwareListener3Destination"></Constant>
<!-- LoftwareListenerXNumConnections: Set to 0 to disable Listener -->
<Constant Name="LoftwareListener1NumConnections">1</Constant>
<Constant Name="LoftwareListener2NumConnections">0</Constant>
<Constant Name="LoftwareListener3NumConnections">0</Constant>
<Constant Name="LoftwareIDocListenerDestination"/>
<!-- LoftwareIDocListenerNumConnections: Set to 1 or more to enable IDocs -->
<Constant Name="LoftwareIDocListenerNumConnections">0</Constant>
<!-- RDI drop location for testing RDI parsing with the connector -->
<Constant Name="RdiManualFileDropPath">C:\Program Files (x86)\Loftware Labeling\SAP Connector\LCfSAPDrop</Constant>
<Constant Name="RdiManualFileDropFilename">*.rdi</Constant>
<!-- XML drop location for testing rules with the connector -->
<Constant Name="XmlTestTriggerFilePath">C:\Program Files (x86)\Loftware Labeling\SAP Connector\LCfSAPDrop</Constant>
<Constant Name="XmlTestTriggerFileName">*.xml</Constant>
<Constant Name="EmailNotificationReturnAddress"/>
<Constant Name="ProvdaOdbcDataSourceName">provda</Constant>
<Constant Name="CacheResetRequestPath">C:\Program Files (x86)\Loftware Labeling\SAP Connector</Constant>
<Constant Name="ProvdaCacheResetRequestFileName">provda_cache_reset_request_log.xml</Constant>
<Constant Name="RudyCacheResetRequestFileName">rudy_cache_reset_request_log.xml</Constant>
<!-- CreateDumpFile: 0 = no 1 = yes -->
<Constant Name="CreateDumpFile">0</Constant>
<!-- DebugLevel: 0 = Debug 1 = Production -->
<Constant Name="DebugLevel">1</Constant>
<Constant Name="EmailAddressOfNlinkAdministrator"/>
<!-- EmailErrorLevel: 0 = Info 1 = Warning 2 = Error -->
<Constant Name="EmailErrorLevel">1</Constant>
    <!-- Use the following setting for BC-XOM integration -->
    <Constant Name="XmiCallback1Destination"></Constant>
```



```
<Constant Name="XmiCallback1Client"></Constant>
<Constant Name="XmiCallback1UserId"></Constant>
<Constant Name="XmiCallback1Password"></Constant>
<Constant Name="XmiCallback1Language">E</Constant>
<Constant Name="XmiCallback2Destination"></Constant>
<Constant Name="XmiCallback2Client"></Constant>
<Constant Name="XmiCallback2UserId"></Constant>
<Constant Name="XmiCallback2Password"></Constant>
<Constant Name="XmiCallback2Language">E</Constant>
<Constant Name="XmiCallback3Destination"></Constant>
<Constant Name="XmiCallback3Client"></Constant>
<Constant Name="XmiCallback3UserId"></Constant>
<Constant Name="XmiCallback3Password"></Constant>
<Constant Name="XmiCallback3Language">E</Constant>
```

```
<!-- The 'init' command issued via the CLI will reference the "LoftwareWebServicePortSynch" setting - remember to
add the '/synch/' URI to the command line parameter -->
```

```
<Constant Name="LoftwareWebServicePortSynch">8081</Constant>
```

```
<!-- The 'submit' command issued via the CLI will reference the "LoftwareWebServicePortAsynch" setting. -->
```

```
<Constant Name="LoftwareWebServicePortAsynch">8080</Constant>
```

```
<!-- The following settings are used for replacing the XMI Spooler status callback with a DB implementation. -->
```

```
<Constant Name="LcSAPTestMode">FALSE</Constant>
```

```
<Constant Name="LcSAPTestOdbcDataSourceName"></Constant>
```

```
<Constant Name="LcSAPTestDatabaseUserId"></Constant>
```

```
<Constant Name="LcSAPTestDatabasePassword"></Constant>
```

```
<!-- The following setting is used with bulk job status update functionality -->
```

```
<Constant Name="LoftwareBulkJobStatusLimit">10</Constant>
```

```
<!-- The following settings are used with the RDI parsing and paging functionality -->
```

```
<Constant Name="RDI Parse A Segment">FALSE</Constant>
```

```
<Constant Name="RDI Parse R Segment">FALSE</Constant>
```

```
<Constant Name="RDI Parse M Segment">FALSE</Constant>
```

```
<Constant Name="RDI Parse S Segment">FALSE</Constant>
```

```
<Constant Name="RDI Parse P Segment">FALSE</Constant>
```

```
<Constant Name="RDI Parse I Segment">FALSE</Constant>
```

```
<Constant Name="RDI Parse C Segment">FALSE</Constant>
```

```
<Constant Name="RdiNewLabelOnRepeatElement">FALSE</Constant>
```

```
</DefaultEnvironment>
</Constants>
```

NLINKPassword.exe

For BC-XOM integration, a utility called NLINKPassword.exe is available for encrypting passwords. The encrypted password can then be copied and pasted into the NLINK Configuration.xml file. Unencrypted passwords will not work. The default location for NLINKPassword.exe after installation is ... \Software Labeling \SAP Connector \Config.

1. Open NLINKPassword.exe. Enter the **Password** and **Confirm Password**. The **Encrypted Password** is calculated and displayed.

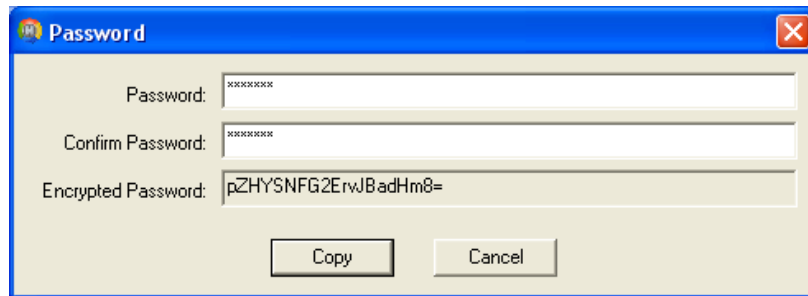

2. Click **Copy**.
3. Open the NLINK Configuration.xml file and locate the XmiCallback[x] Password entry for the appropriate XmiCallback[x]UserId. Paste the Encrypted Password into this entry. For example:

```
<Constant Name="XmiCallback1Password" >pZHYSNFG2ErvJBadHm8=</Constant Name >
```

4. Save the NLINK Configuration.xml file.

Configure Saprfc.ini

This is the RFC_INI Environment Variable. Saprfc.ini is required by the SAP Software Development Libraries to provide connectivity to your SAP systems. The Software Connector for SAP Applications system requires an entry for each SAP instance you use with for the Software Connector for SAP Applications system to connect back to.



Default Location

Window Server 2008: C:\ProgramData\Loftware Inc\Labeling\SAP Connector\Config

Windows Server 2003: C:\Program Files\Loftware Labeling\SAP

Saprfc.ini Format

Note: The PROGID entry in the saprfc.ini file is case sensitive and must match the transaction SM59 entry in SAP exactly. Instructions for configuring the RFC with SM59 are described in the [SAP ABAP Requirements for Label Printing](#) section.

For more details on settings, see [The SAPRFC.INI File](#) on the SAP help system, help.sap.com.

Type "R" is for the Connector utilizing the RFC Interface. SAP sends jobs to the Connector.

Type "A" is for SAP Query (Logic). The Connector queries SAP. For BC-XOM integration, Saprfc.ini has other entries as noted below.

Saprfc.ini for BC-XOM Integration

The Loftware Connector for SAP Applications system requires an entry for each SAP instance that you use for the Loftware Connector for SAP Applications system to connect back to. For BC-XOM integration, the saprfc.ini entries follow a different format from the typical RFC integration format:

```
DEST=[DESTINATION_NAME]
TYPE=A
ASHOST=[SAPHOSTNAME]
SYSNR=00
```

- `TYPE` is set to "A" in almost all cases of BC-XOM integration, unless you are using SAP R/3 Load Balancing, in which case, the `TYPE` must be set to "B".
- `DEST` is the destination name used to identify this SAP instance to the Loftware Connector for SAP Applications and can be set to anything as long as it matches one of the `XmiCallbackxDestination` settings in the "NLINK Configuration.xml" file.
- `ASHOST` is set to the host name of the SAP instance. Most of the time this should be all that is needed, but the `GWHOST` and `GWSERV` settings may be required at some sites.
- `SYSNR` is the system number for the SAP instance that you are connecting to. Usually this is 00, 01, 02, or 03, but it could go higher.



Sample Saprfc.ini file

```
/*-----*/
/*              SAPRFC.INI              */
/* The 'saprfc.ini' file must be in the same directory as the RFC */
/* client or server program or it can completely be defined by the */
/* environment variable RFC_INI with a full path and file name. */
/* Example on WINDOWS: set RFC_INI=d:\rfctest\saprfc.ini. */
/* Example on AS/400: ADDENVVAR ENVVAR(RFC_INI) VALUE('/QSYS.LIB/ */
/*              R340ARFC.LIB/INI.FILE/SAPRFC.MBR') */
/*-----*/
/*-----*/
/* Type R: Register a RFC server program at a SAP gateway */
/*              or connect to an already registered RFC server program */
/*-----*/
DEST=LOFTWARE1
TYPE=R
PROGID=
GWHOST=
GWSERV=

/*-----*/
/* Type A: R/3 system - specific application server */
/*-----*/
DEST=
TYPE=A
ASHOST=
SYSNR=00

/*-----*/
/* Type B: R/3 system - Use Load Balancing feature of R/3 3.0 */
/*-----*/
DEST=
TYPE=B
MSHOST=
```



Configuring the Loftware Connector for SAP Applications Command Line

The Loftware Connector for SAP ApplicationsCommand Line is a utility that is executed by the SAP Spooler when a Print Job is submitted from SAP. The Loftware Connector for SAP ApplicationsCommand Line and supported calls are described in the next section.

Deploy the CLI

This step should be performed by a system administrator on the SAP system. The setup for the Loftware Connector for SAP ApplicationsCommand Line (CLI) requires moving the lcf.sap.jar file into a directory that the SAP instance can access.

Note: It is strongly recommended that each application server be set up with its own CLI and a uniquely named CLI log file.

- From the Loftware Connector for SAP ApplicationsCLI installation folder, FTP the lcf.sap.jar and Log4j.properties files to the SAP system directory.

Note: By default the CLI is installed to C:\Program Files\Loftware Labeling\SAP Connector\Cli.

The CLI can be any location, as long as the ROMS definition in SPAD has the appropriate path in the OMS Submit Command.

To test the connection between the Loftware Connector for SAP ApplicationsCommand Line and the Loftware Connector for SAP Applications, you can issue a test `init` command.

For example

```
java -jar lcf.sap.jar init <LCfSAPHOSTNAME>:<LoftwareWebServicePortSynch>/synch/ x x x x
```

Since you are not supplying real information for `x`, this will return an error from the Loftware Connector for SAP Applicationssystem that the OMS is not configured.

Loftware Connector for SAP ApplicationsCommand Line

This section is included for information purpose only.

The Loftware Connector for SAP ApplicationsCommand Line Interpreter (CLI) is an application that communicates with the SAP BC-XOM interface using RDI files as a bridge between the SAP's OMS and the Loftware Connector for SAP Applications.

The CLI is configured when the Loftware Connector for SAP ApplicationsBC-XOM interface is set up by a system administrator on the SAP system.

Supported Calls

The CLI is accessible by SAP via a command line call. However, it may also be run via traditional command line calls. The following calls are supported:

init

The init command will call the InitializeOms Web Service Call and pass the remaining parameters in the order they are received.

```
java -jar lcfsap.jar init <LCfSAPHOSTNAME>:<LoftwareWebServicePortSynch>/synch/ param2 param3 ROMSNAME CALLBACKTARGET
```

Parameters

- `LoftwareWebServicePortSynch` is the synchronous web service port defined in NLINK Configuration.xml file.
- `LCfSAPHOSTNAME` is the URL from SAP. For Loftware Connector for SAP Applications, this is the hostname of the machine that Loftware Connector for SAP Applications is running on.
- `Param2` (r3RomsFlags)
- `Param3` (romsFlags)
- `ROMSNAME` (romsName) is the name of the Real Output Management System (ROMS) configured in SAP. If there are several, then there will be several of this call. This call happens when SAP starts up.
- `CALLBACKTARGET` (sapCallbackInstance) is the value in “Server name” that you get from SAP if you do System/Status from the menu. It follows the pattern `hostname_systemid_instance`. For example: `sap46_JS1_00`.

Output

- stdout
- stderr

submit

The submit command will call the SubmitRdiToLps Web Service Call and pass the remaining parameters in the same order they are received.

```
java -jar lcfsap.jar submit <LCfSAPHOSTNAME>:<LoftwareWebServicePortAsynch> SPOOLID RMG DEVICE FILENAME CALLBACKTARGET
```



Parameters

- `LoftwareWebServicePortAsynch` is the asynchronous web service port defined in `NLINK Configuration.xml` file.
- `LCfSAPHOSTNAME` is the URL from SAP. For the Loftware Connector for SAP Applications, it is the hostname of the machine that the Loftware Connector for SAP Applications is running on.
- `SPOOLID` (spoolid) is assigned by SAP and is part of what is used to send the status back to SAP. For example: 000000967900007
- `RMG` (replyMessageGroup) is the Reply Message Group that SAP generates for either the ROMS or LOMS
- `DEVICE` (destinationDevice) is the output device that the user chose when the spool request was submitted.
- `FILENAME` is the full path and filename of the spool file on the SAP machine that holds the RDI data.
- `CALLBACKTARGET` (sapCallbackInstance) is the value in "Server name" that you get from SAP if you select System/Status from the menu. It follows the pattern `hostname_systemid_instance`.

Output

- `stdout`
- `stderr`

version

The `version` command returns the version number of the Command Line module installed on a machine. It is read from the jar file and displayed on `stdout`.

```
java -jar lcfsap.jar -version
```

Configuring SAP

This step should be performed by a system administrator within SAP.

This section describes the configuration required within SAP to get the full BC-XOM interface with status back working properly. To do any of the following configuration, the SAP user account must have administrative access to the SAP Spool Administration (SPAD) and related transactions. All of the steps below start from the SPAD transaction with either Extended or Full Administration Mode enabled at the transaction.

Configure ROMS

The Real Output Management System (ROMS) must be set up so that SAP knows how to initialize the OMS component of the Loftware Connector for SAP Applications.

1. From the initial SPAD screen, select the **Output management systems** tab, and then click **Display** next to **Real Output Management Systems**. This will display the list of ROMS.

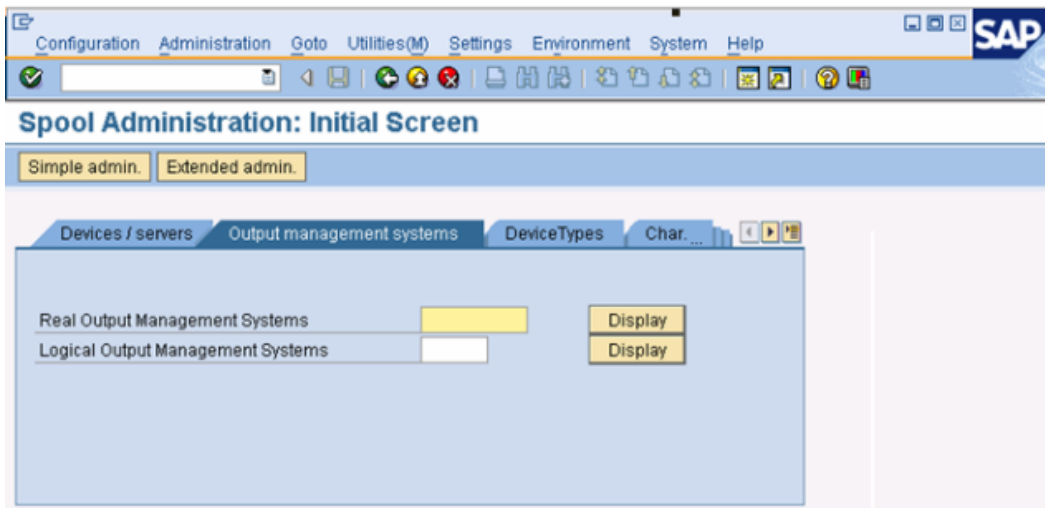



Figure 5.7: SAP Spool Administration Screen

2. Switch into edit mode by clicking the  (pencil) icon.
3. Create a new ROMS by clicking the  (paper) icon.
4. Under the **OMS Description** section, enter a name and a description.



5. Under the **OMS Attributes** section:
 - a. In the **Tasking** subsection, select **Command line**.
 - b. In the **Job Status** subsection, select the **Callback**.
6. Under the **SAP Configuration** section:
 - a. Select the **Initialization Instance** that this ROMS will use.
 - b. Enter the **Initialization Command** for the Loftware Connector for SAP Applications Command Line Interpreter directly into SAP.

For Example

```
java -jar lcfsap.jar init <LCfSAPHOSTNAME>:<LoftwareWebServicePortSynch>/synch/ "&E3" "&E4" "&ER" "&Es"
```

Important: The quotation marks in the example are very important; make sure they are included as shown.

Note: Avoid spaces within paths, if possible.

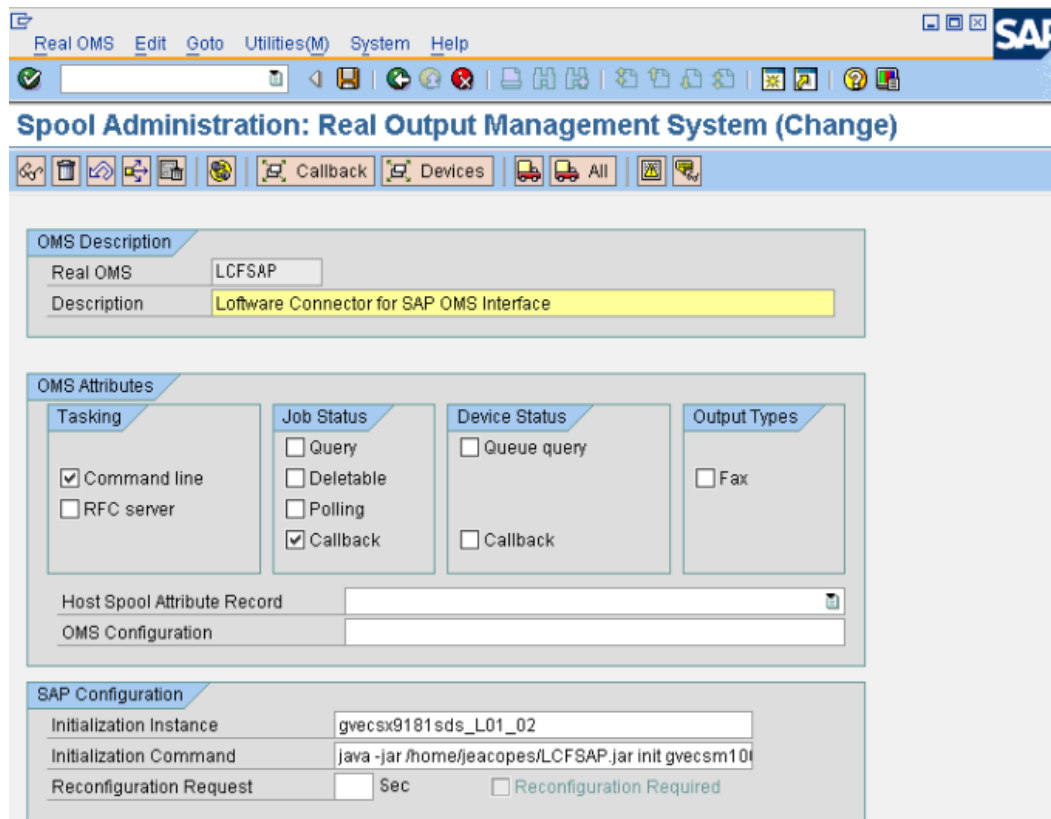



Figure 5.8: SAP Spool Administration ROMS Screen

7. Save the ROMS.

Configure LOMS

The next step in BC-XOM integration is to set up the Logical Output Management System (LOMS). This configuration is what SAP uses to actually submit the job to the Loftware Connector for SAP Applicationssystem.



1. From the main SPAD screen, select the **Output management systems** tab, and then click **Display** next to **LOMS**. This will display the list of LOMS.
2. Click new  to create a new LOMS.
3. Assign a Name and **Description** for the LOMS.
4. On the SAP configuration tab:
 - a. Select the ROMS that was created in the previous section.
 - b. Select the same instance from the previous section as the **Target for callback**.

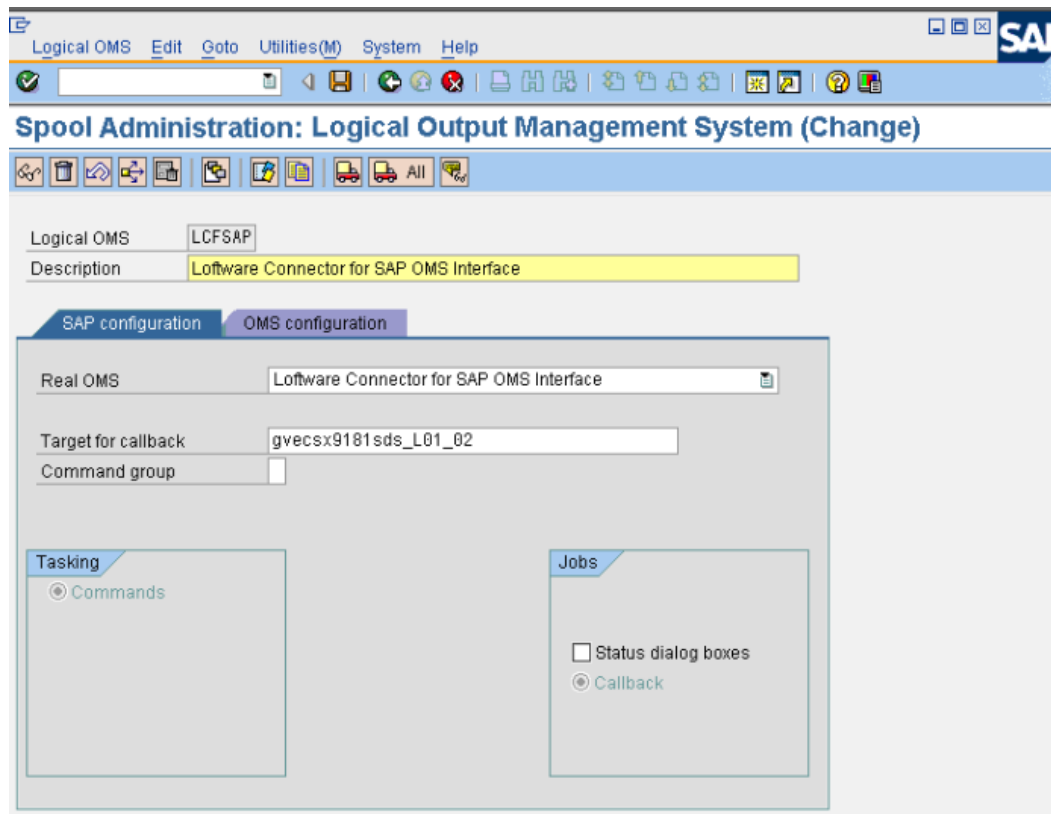

Figure 5.9: SAP Spool Administration LOMS Screen

5. Save the LOMS.

Configure LOMS Commands

As a sub-step of the LOMS Configuration, you must also specify the command to be issued when the LOMS is invoked.



1. From the LOMS display screen, enter the **Commands** screen by clicking the cascading paper icon.
2. Select the **Operating System** that SAP is running under.

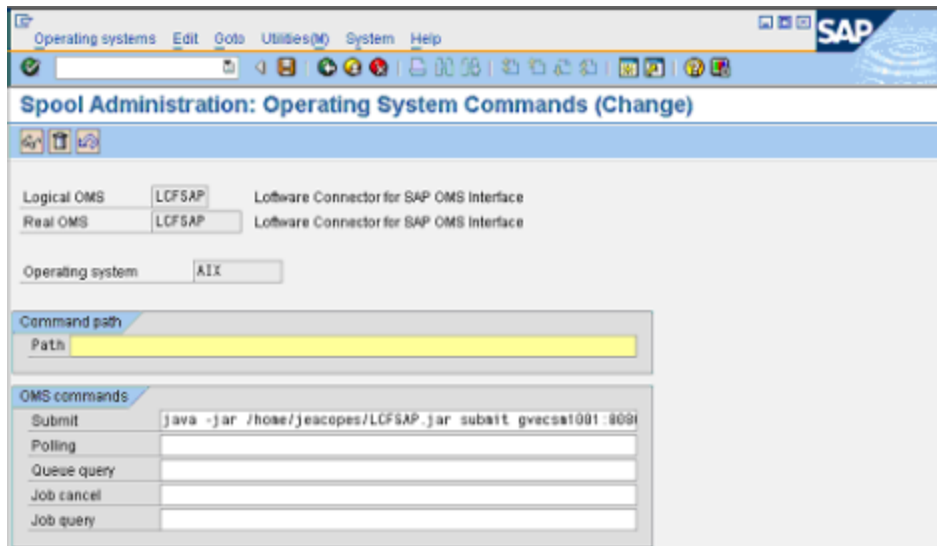

Figure 5.10: SAP Spool Administration Operating System Commands Screen

3. Under the **Command path** section, you can optionally set the working directory where the command exists (in the case of java, this location is the java bin directory).

Note: Most Java installations add the java bin directory to the OS's environment variables, and therefore, this may not be required.

4. Under the **OMS commands** section, enter the submit command for the Loftware Connector for SAP Applications Command Line directly into SAP. The submit command is:

```
java -jar lcf.sap.jar submit <LCfSAPHOSTNAME>:<LoftwareWebServicePortAsynch> "&EI" "&EG" "&P" "&F" "&ES"
```

Important: The quotation marks in the example are very important; make sure they are included as shown.

Note: Avoid spaces within paths, if possible.

5. Save the command and return to the SPAD screen.

Configure Output Device

This is the final step for hooking up SAP to the Loftware Connector for SAP Applications Command Line. In this step, an Output Device (SAP Printer) is set up and associated to the LOMS. You may end up creating many SAP Output Devices as an association of one SAP Output Device to one Loftware printer.

1. Select the **Devices / servers** tab.

Spool Administration: Initial Screen

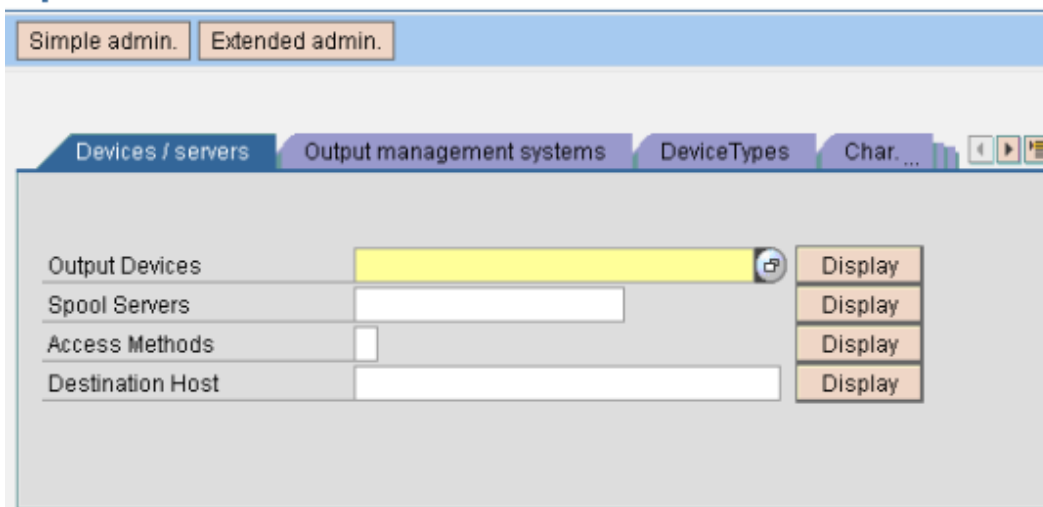



Figure 5.11: SAP Spool Administration Devices / servers Tab

2. Click the Display next to **Output Devices**.
3. When the list of output devices is shown, click the  (pencil) to enter edit mode.



4. Click new  (paper) to create a new Output Device.
5. On the **DeviceAttributes** tab, set the **Device Type** to **PLAIN: SAPscript RDI(ASCII)**

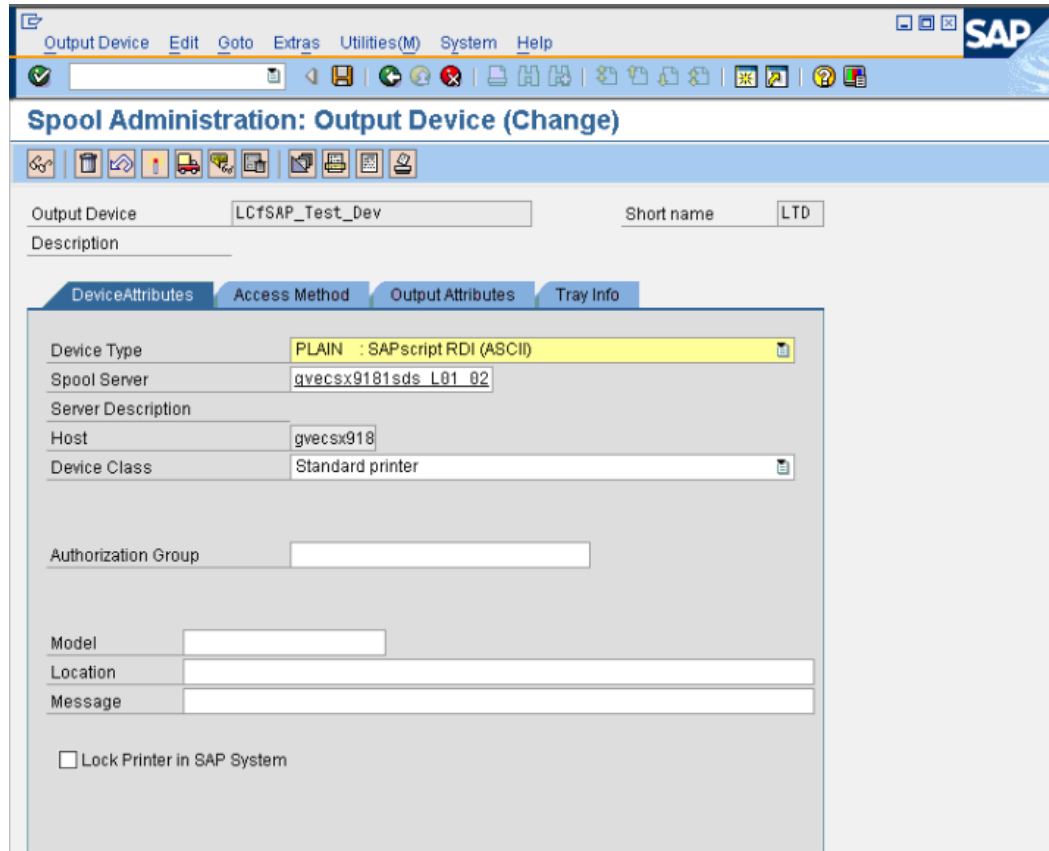

Figure 5.12: SAP Spool Administration Output Device Screen

6. On the **Access Method** tab:

- a. Set the Host Spool Access Method to E: External output management system
- b. Set the Host printer name.
- c. Set the Logical OMS to the one created in the previous sections.
- d. Save the Output Device.

Loftware Connector for SAP Applications BC-XOM Status Codes

The following status codes are returned to SAP from the Loftware Connector for SAP Applications:

Internal Status	Status Text	JOBSTATE	CLASSCODE	AREACODE	RESULTCODE
0	Printed.	Complete, cannot be resubmit	Information (no error)	Printing	Printed
1	Job(s) <...> sent asynch to LPS.	Complete, cannot be resubmit	Information (no error)	Printing	Possibly printed
2	Output request <...> in process.	Pending, waiting in queue	Information (no error)	Printing	Possibly printed
1000	Invalid Label	Cancelled	Error	Formatting	Not printed
1001	Invalid Printer	Cancelled	Error	Formatting	Not printed
1002	Invalid Label/Printer	Cancelled	Error	Formatting	Not printed
1003	Label missing required fields	Cancelled	Error	Formatting	Not printed
1004	Incomplete request	Cancelled	Error	Formatting	Not printed
1498	No print request sent to LPS.	Cancelled	Problem not requiring	Formatting	Not printed



Internal Status	Status Text	JOBSTATE	CLASSCODE	AREACODE	RESULTCODE
			intervention		
1499	Unexpected error.	Cancelled	Error	Formatting	Not printed
1500	LPS Unreachable	Cancelled	Problem requiring intervention	Connection, network	Not printed
1501	LPS Critical Failure	Cancelled	Problem requiring intervention	Printing	Not printed
1502	LPS Printed with Errors	Complete, cannot be resubmit	Problem not requiring intervention	Printing	Possibly printed
1503	LPS Printer Error	Cancelled	Problem requiring intervention	Printing	Not printed

Loftware Connector for SAP Applications web.config

The web.config file is the IIS web configuration file for the Loftware Connector for SAP Applications Configuration and Diagnostics interface. This file defines the Application log locations, Component Versions and Windows Authentication.

During a standard installation, this file is copied to c:\inetpub\wwwroot\sapcon

The following table describes the settings available in web.config.

Important! If you installed the Loftware Connector for SAP Applications on a failover cluster, when you make changes to web.config you must make the changes on each node of the cluster. Restart IIS on each node after making changes to the web.config file.

Setting	Default	Default - Cluster	Associated File	Note
LogLevel	5			



Setting	Default	Default - Cluster	Associated File	Note
LogFileMaxSize	2500000			KB
SiteName	LWSAPConfigUI			
LogDir	~/logs		SAPCONNECTCONFIG.log	
LogName	SAPCONNECTCONFIG.log			
LoftwareBaseDir	C:\Program Files (x86)\Loftware Labeling		WatchDogNt.exe	
LoftwareLwEntUpBaseDir	C:\Program Files (x86)\Loftware Labeling		LwEntUp.exe, LwEntUp.exe.config	
LoftwareAppDataSAPLogsDir	C:\Program Data\Loftware Inc\Labeling\SAP Connector\logs		LwEntUp.log, SAP_Interface.log	
LoftwareAppDataSAPConfigDir	C:\Program Data\Loftware Inc\Labeling\SAP Connector\Config	\\VirtualHost\loftware\$\SAP Connector\Config	saprfc.ini	
LoftwareAppDataSAPConfigMetaDataDir	C:\Program Data\Loftware Inc\Labeling\SAP Connector\Config\Metadata	\\VirtualHost\loftware\$\SAP Connector\Config\metadata	Provda.mdb, Loftware Label Printing.nlk	
LoftwareSAPServerDir	C:\Program Files (x86)\Loftware Labeling\SAP Connector\NLINK Server		NLink.exe	
LoftwareSAPConfigDir	C:\Program Files (x86)\Loftware Labeling\SAP Connector\Config		NLINK Configuration.xml	
LoftwareSAPLogsDir	C:\Program Files (x86)\Loftware		NLINK SapRFCListener CoNNECTor	



Setting	Default	Default - Cluster	Associated File	Note
	Labeling\SAP Connector\logs		Error.Log,NLink.trc	
LoftwareSAPDropDir	C:\Program Files (x86)\Loftware Labeling\SAP Connector\LCfSAPDrop	\\VirtualHost\loftware\$\SAP Connector\LCfSAPDrop		
CacheResetRequestDir	C:\Program Files (x86)\Loftware labeling\SAP Connector	\\VirtualHost\loftware\$\SAP Connector	rudy_cache_reset_request_log.xml, provda_cache_reset_request_log.xml, lwentup_resync_request_log.xml	
RudyCacheResetRequestFileName	rudy_cache_reset_request_log.xml			
ProvdaCacheResetRequestFileName	provda_cache_reset_request_log.xml			
LwEntUpResyncRequestFileName	lwentup_resync_request_log.xml			
LoftwareLwEntUpLogName	LwEntUp.log			
LPSServerName	None			The name of the server where the Loftware Print Server is located.
LwEntUpServerName	None			The name of the server where the Loftware Enterprise Update Service is located.



Setting	Default	Default - Cluster	Associated File	Note
SAPConnectorServerName	None			The name of the server where the Loftware Connector for SAP Applications is located.
DateFormat	yyyy/MM/dd			
TimeFormat	HH:mm:ss.ffff			
GridPageSize	10			The number of rows displayed on the Configuration User Interface pages.
NumFileNames	5			
CacheResetRequestMaxEntries	1000			

SAP ABAP Requirements for Label Printing

The Loftware Connector for SAP Applications uses an SAP RFC Listener to receive print requests initiated by the SAP system. Similar to receiving IDocs, the Listener will register with SAP. This call will take the form of a CALL FUNCTION ... DESTINATION statement in an ABAP program in SAP. There are a few configuration requirements in the SAP system to prepare to use this Connector:

- RFC Destination
- SAP User Id
- ABAP “test code”
- Implementation Considerations

For more information on ABAP programming, see [ABAP Programming](#) on the SAP help system, help.sap.com.

RFC Destination

Your SAP system must have an RFC Destination for the Loftware interface configured in transaction SM59. The name is configurable, to adhere to your SAP standards. The Connection Type should be T (TCP/IP connection) and the Activation Type should be Registration. The registering Program Id is also configurable, although you will need to know this value in order to set up the corresponding definition in the saprfc.ini file.

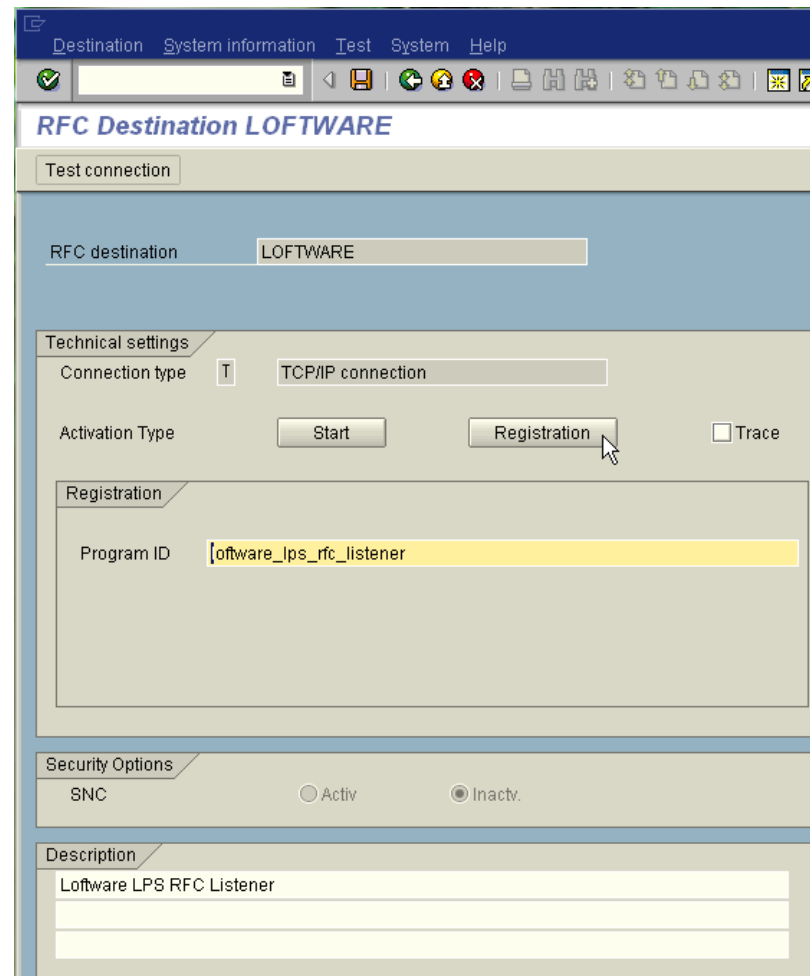

Figure 5.13: Example RFC Destination in SM59

Note: The **Program ID** matches PROGID in saprfc.ini file



Note: This RFC is a Destination RFC so no SAP function is required to be created for the RFC. The RFC functions being called reside in the Loftware Connector for SAP Applications. The only SAP coding required is the ABAP call to trigger the label print request.

The screenshot shows the SAP SM59 configuration interface for an RFC destination. The destination name is 'LOFTWARE' and the connection type is 'TCP/IP connection'. The description is 'Loftware LPS RFC Listener'. The 'Special Options' tab is active, showing the following settings:

- Special Flags:** 'Trace' and 'Slow RFC Connection' are unchecked. A button for 'RFC Bit Options' is present.
- Character Width in Target System:** 'Non-Unicode' is selected. The 'MDMP Settings' sub-section has 'Inactiv' selected. 'Unicode' is also selected.
- Character Conversion:** 'Default Setting' is selected. The error indicator is set to 'U+ 0023'.

Figure 5.14: SM59 Unicode Options

Note: For Unicode SAP Instances, on the **Special Options** tab, set the **Char width Target System** to Unicode.

In addition to the entry in SM59, you will need a destination definition in the saprfc.ini file. The name of the destination definition (DEST) does not need to match the name of the RFC Destination in SM59, but the program id (PROGID) must match.



Example Destination Definition in saprfc.ini File

```
*****  
* Loftware *  
*****  
  
DEST=LOFTWARE  
TYPE=R  
PROGID=loftware_lps_rfc_listener  
GWHOST=sap46  
GWSERV=sapgw00  
RFC_TRACE=0
```

Note: DEST matches External System Attribute in Connector Metadatabase (LOFTWARE1) DEST does not need to match the RFC destination name in the previous figure. PROGID matches Program ID in RFC Destination (SM59)

For more information on RFC Destinations, see [Connection Establishment Using Destination \(SM59\)](#) on the SAP help system, help.sap.com.

Communication Modes

There are three different modes of communication between SAP and the Loftware Print Server.

- **Asynchronous from SAP** (LOFTWARE_PRINT_REQUEST) – The call from SAP to the Loftware Connector for SAP Applications is asynchronous by nature and thus has no confirmation or status returned.
- **Asynchronous to LPS** (LOFTWARE_PRINT_REQUEST_ACK) – The call will return after the job has been accepted by the LPS or when a high-level error occurs.
- **Synchronous to LPS** (LOFTWARE_PRINT_REQUEST_CONFIRM) – The call will return after the job as been delivered to the printer or when a high-level or printer-level error occurs.

RFC Signatures

Example CALL FUNCTION statements for the three communications modes are as follows.

```
LOFTWARE_PRINT_REQUEST  
call function  
'LOFTWARE_PRINT_REQUEST'
```



```
destination
'LOFTWARE'

exporting
LABEL= label_name
PRINTER= printer_name
JOBNAME= job_name
QUANTITY= quantity
DUPLICATES= duplicates

importing
tables
LABEL_FIELDS= fields.

exceptions
COMMUNICATION_FAILURE= 1 message msg_text
SYSTEM_FAILURE= 2 message msg_text
OTHERS= 3
```

LOFTWARE_PRINT_REQUEST_ACK

```
call function
'LOFTWARE_PRINT_REQUEST_ACK'

destination
'LOFTWARE'

exporting
LABEL= label_name
PRINTER= printer_name
JOBNAME= job_name
QUANTITY= quantity
DUPLICATES= duplicates

importing
CONFIRMATION= confirmation_message

tables
LABEL_FIELDS= fields

exceptions
COMMUNICATION_FAILURE= 1 message msg_text
SYSTEM_FAILURE= 2 message msg_text
OTHERS= 3
```



LOFTWARE_PRINT_REQUEST_CONFIRM

```
call function
'LOFTWARE_PRINT_REQUEST_CONFIRM'

destination
'LOFTWARE'

exporting
LABEL= label_name
PRINTER= printer_name
JOBNAME= job_name
QUANTITY= quantity
DUPLICATES= duplicates

importing
CONFIRMATION= confirmation_message

tables
LABEL_FIELDS= fields

exceptions
COMMUNICATION_FAILURE= 1 message msg_text
SYSTEM_FAILURE= 2 message msg_text
OTHERS= 3
```

Data Types

The parameter data types should be defined in SAP as follows.

Export Parameters	LABEL	CHAR255	Label, Label Type or Label Group
	PRINTER	CHAR50	Printer name
	JOBNAME	CHAR255	Unique name for job, echoed in LPS
	QUANTITY	INT	
	DUPLICATES	INT	



Import Parameters	CONFIRMATION	STRUCTURE ID (INT) MSG (CHAR32)	Structure describing the results of the print request
Table Parameters	LABEL_FIELDS	STRUCTURE: LABELNUM (INT) FIELDNAME (CHAR60) FIELDVALUE (CHAR1000)	List of field names and values

The LABELNUM value in the LABEL_FIELDS structure is used to send multiple labels in a single print request. All of the fields belonging to a particular label should have the same LABELNUM value. If submitting a request for a single label “Job” this value can be 0 (zero) for all fields. See the sample below for the structure of LABEL_FIELDS to print one label.

There will be a row for each field required.

LABELNUM	FIELDNAME	FIELDVALUE
0	PART_NUMBER	GR1287654
0	CUSTOMER_NUMBER	76234

Each of the export parameters can be overridden in any particular label by including a LABEL_FIELDS record with the appropriate keyword in the FIELDNAME (with the exception of PRINTER). The keywords are:

- `_LABEL`
- `_JOBNAME`
- `_QUANTITY`
- `_DUPLICATES`
- `_TRAY`

- `_PAGES`
- `_WAITFORSTATUS`

Stacking Label Requests

Multiple Label Requests can be included in a single RFC call.

Label requests contained in a Stacked Job must be destined for a single printer type.

The LABELNUM Field in the LABEL_FIELDS structure represents the individual label request. For each new label request, this number must be incremented. See the sample below for the structure of LABEL_FIELDS to print 2 labels. There will be a row for each field required.

LABELNUM	FIELDNAME	FIELDVALUE
0	PART_NUMBER	GR1287654
0	CUSTOMER_NUMBER	76234
1	PART_NUMBER	AB9867221
1	CUSTOMER_NUMBER	998345

Exceptions

If the call from SAP is synchronous, the following SAP ABAP Exceptions may be raised.

Value	Short Msg	Description
1	COMMUNICATION_FAILURE	System-level exception indicating a connection or communications failure
2	SYSTEM_FAILURE	System-level exception indicating any other unidentified failure
3	OTHERS	



SAP ABAP Confirmation Values

The result of the job submission is reflected in the Confirmation Structure (Import Parameter). The Structure consists of two members: the ID (an INT) and the MSG (CHAR32).

Based on the ranges, it is possible to code your ABAP to handle future error codes by checking the ID's Range.

ID Range	ID (Value)	MSG (Description)
< 1000 SUCCESS	0	Printed
	1	Accepted by LPS
1000-1499 Filter Related Errors	1000	Invalid Label
	1001	Invalid Printer
	1002	Invalid Label/Printer
	1004&& <=1499	Various Connector-Determined Errors
> 1500 LPS Related Errors	1500	LPS Unreachable
	1501	LPS Critical Failure
	1502	LPS Printed with Errors
	1503	LPS Printer Error
	>=1504	Other LPS Errors



The following tables describe some possible errors, the message returned to SAP, and the result of the error. Additional logging appears in the sap_interface.log

The Effect of the PassThroughAllowed Setting in NLINK Configuration.xml

Changing the PassThroughAllowed setting in NLINK Configuration.xml affects certain confirmation values. See the following tables for the message differences.

```
<!-- PassThroughAllowed: Leave this true if you intend to have Rule Assignments of DEFAULT-DEFAULT-DEFAULT -->  
<Constant Name="PassThroughAllowed">TRUE</Constant>
```

To Turn Off PassThroughAllowed in the Loftware Connector for SAP Applications Version 1.5.x

1. Change the PassThroughAllowed Constant in NLINK Configuration.xml to False.

```
<!-- PassThroughAllowed: Leave this true if you intend to have Rule Assignments of DEFAULT-DEFAULT-DEFAULT -->  
<Constant Name="PassThroughAllowed">FALSE</Constant>
```

Asynchronous from SAP: LOFTWARE_PRINT_REQUEST

No confirmation or status is returned. Message displayed is "0."



Asynchronous to LPS: LOFTWARE_PRINT_REQUEST_ACK

Issue	Message: Pass Through On	Message: Pass Through Off	Result
None	1 Job [Job ID] sent asynch to LPS	1 Job [Job ID] sent asynch to LPS	Printed
Label Not Available	1 Job [Job ID] sent asynch to LPS	0	Job Sent and Failed or Job Not Sent (Pass Through Off)
Label Not on Disk nor Database	N/A	0	Job Not Sent
Printer Not Available	0	0	Job Not Sent
Label and Printer Do Not Match	1 Job [Job ID] sent asynch to LPS	1 Job [Job ID] sent asynch to LPS	Job Sent and Failed
Label Not Printable	1 Job [Job ID] sent asynch to LPS	1 Job [Job ID] sent asynch to LPS	Job Sent and Failed
Label Missing Variable Image	1 Job [Job ID] sent asynch to LPS	1 Job [Job ID] sent asynch to LPS	Job Sent and Failed
Partial Success	1 Job [Job ID] sent asynch to LPS	1 Job [Job ID] sent asynch to LPS	Job Sent and Failed/Printed
Label Missing Required Fields	1 Job [Job ID] sent asynch to LPS	1 Job [Job ID] sent asynch to LPS	Printed
Connector Errors	TBD	TBD	TBD
LPS Unreachable	1500 LPS Unreachable	1500 LPS Unreachable	Job Not Sent



Issue	Message: Pass Through On	Message: Pass Through Off	Result
Printer Timeout	1 Job [Job ID] sent asynch to LPS	1 Job [Job ID] sent asynch to LPS	Job Sent and Pending



Synchronous to LPS: LOFTWARE_PRINT_REQUEST_CONFIRM

Issue	Message: Pass Through On	Message: Pass Through Off	Result
None	0 Printed	0 Printed	Printed
Label Not Available	1501 LPS Critical Failure	1002 Invalid Label/Printer	Job Sent and Failed or Job Not Sent (Pass Through Off)
Label Not On Disk nor Database	N/A	1000 Invalid Label	Job Not Sent
Printer Not Available	1001 Invalid Printer	1001 Invalid Printer	Job Not Sent
Label and Printer Do Not Match	1501 LPS Critical Failure	1501 LPS Critical Failure	Job Sent and Failed
Label Not Printable	1501 LPS Critical Failure	1501 LPS Critical Failure	Job Sent and Failed
Label Missing Variable Image	1501 LPS Critical Failure	1501 LPS Critical Failure	Job Sent and Failed
Partial Success	1502 LPS Printed with Errors	1502 LPS Printed with Errors	Job Sent and Failed/Printed
Label Missing Required Fields	0 Printed	0 Printed	Printed
Connector Errors	TBD	TBD	TBD
LPS Unreachable	1500 LPS Unreachable	1500 LPS Unreachable	Job Not Sent
Printer Timeout	1503 LPS Printer Error	1503 LPS Printer Error	Job Sent and Pending

Note: The fact that labels with missing data for required fields are successfully printing and returning successful "0 Printed" confirmation values is a known issue that is being investigated for a future release.



Implementation Considerations

Calls to an RFC Destination may be placed in ABAP code in several places in SAP. These include user exits, business add-ins, workflow, output determination and custom function modules, reports or transactions.

It is important to understand that initiating an RFC from inside SAP via the CALL FUNCTION ... DESTINATION statement will trigger a database commit in the SAP system. For this reason, it may not be desirable to make a synchronous call from certain locations.



Troubleshooting

Issue	Solution
<p>In the Event Viewer after starting the Loftware Connector for SAP Applications service.</p> <pre>External System: CoNNeCtor:: SAP RFC Listener CoNNeCtor: Unable to connect to SAP. Will retry. RFC_ERROR_PROGRAM RFC subsystem not yet initialized [External System ID = 13]</pre>	<p>Verify that you have configured the connection to your SAP system.</p> <p>See Configure Saprfc.ini and Configure NLINK Configuration.xml in this guide.</p>
Issue	Solution
<p>There is no information in the Rule Type drop-down field of the Add Rule page.</p> <p>The Edit Server page is empty.</p>	<p>Add the <code>http://localhost/sapcon</code> website to the Trusted sites zone.</p> <p>Or</p> <p>Connect As a specific User</p> <ol style="list-style-type: none">1. Open the IIS Manager2. Select the sapcon site3. Select Basic Settings on the right hand side.4. Select Connect as.5. Select Specific User.6. Select Set.7. Enter a User name and password.



Issue	Solution
Menus in the Configuration User Interface appear off center of the selected tab.	On the Compatibility View Settings dialog in Internet Explorer, clear the check box next to Display intranet sites in Compatibility View . Add the <code>http://localhost/sapcon</code> website to the Trusted sites zone.
Adding a second Element in the Format Path Definition Page causes a crash on Windows Server 2003.	Verify that you have installed the latest critical updates through Windows Update. Check specifically for the following update: Microsoft .NET Framework 3.5 Service Pack 1 and .NET Framework 3.5 Family Update for .NET versions 2.0 through 3.5 (KB951847) x86
"Server Error in '/sapcon' Application" appears when opening the Configuration User Interface in Window Server 2003.	Verify that you have installed the Microsoft .NET Framework 2.0, and registered it with Internet Information Services (IIS). Follow the instructions in Manually registering the .NET Framework 2.0 in Windows Server 2003 (32 Bit) to register the .NET Framework.



Uninstall the Loftware Connector for SAP Applications

1. Open Control Panel | Programs | Uninstall a Program
2. Select **Loftware Connector for SAP**, and click **Uninstall**.
3. Follow any instructions on the screens that appear, and click **Finish** when complete.

Loftware Connector for SAP Applications Configuration and Diagnostics

The Loftware Connector for SAP Applications Configuration and Diagnostics interface is a browser-based tool for the following tasks:

- Defining the routing logic used by the Loftware Connector for SAP Applications
- Configuring Metadata
- Defining certain SAP Interface settings
- Configuring the dynamic Format Path

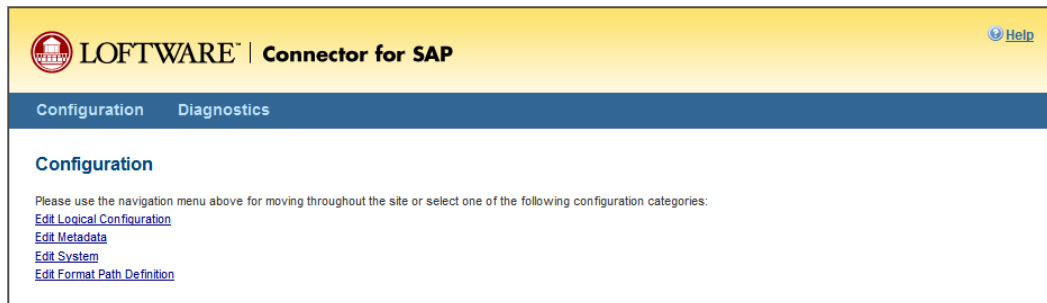

Figure 5.15: Loftware Connector for SAP Applications Configuration Interface Home Page

Open the Loftware Connector for SAP Applications Configuration and Diagnostics Interface

From the server, you can access the Loftware Connector for SAP Applications Configuration and Diagnostics Interface by entering:

```
http://localhost/sapcon
```



From a computer other than the Loftware Connector for SAP Applications server, replace "localhost" with the IP Address of the server hosting the Loftware Connector for SAP Applications.

You may be prompted to enter a Username and Password to open the Loftware Connector for SAP Applications Configuration and Diagnostics Interface. The username must be a user on the Loftware Connector for SAP Applications server.

Note: If you are using an operating system with User Account Control (UAC) enabled to access the Loftware Connector for SAP Applications Configuration and Diagnostics Interface, you should add the sapcon URL to the Trusted Sites list on the Internet Options | Security tab in Internet Explorer.

Defining Labels, Label Types, and Label Groups

Before using any of the Loftware Connector for SAP Applications extended rules capabilities, you must define the labels or label types, and/or label groups to use with them.

Labels, Label Types, and Label Groups are used to generate the label instances passed to the Loftware Print Server in a print request.

- A Label is a specific layout, as defined in the Loftware design tool (Loftware Label Manager). A Label Instance represents a single label - a `<label>` node in the XML data.
- A Label Type refers to one or more similar labels.
- A Label Group consists of two or more Labels to be processed together.
- Combinations of Label, Type and Group will determine which Rules (filters) will be executed.

From the navigation bar, select Configuration | Edit Logic | Edit Labels to add, edit, or delete labels, label types, and label groups. A tabbed interface provides access to these items.

Labels

The Labels page provides an interface for configuring label definitions. Once a label is created, you can associate it with a label type and/or a label group. Initially, only the read-only Default label is available.

Note: A Default label can be used in rule assignments to indicate that the label does not matter when deciding whether to invoke the filter.

Labels and Label Types are mutually exclusive. Rules apply either to a specific label or to all labels of a particular label type.

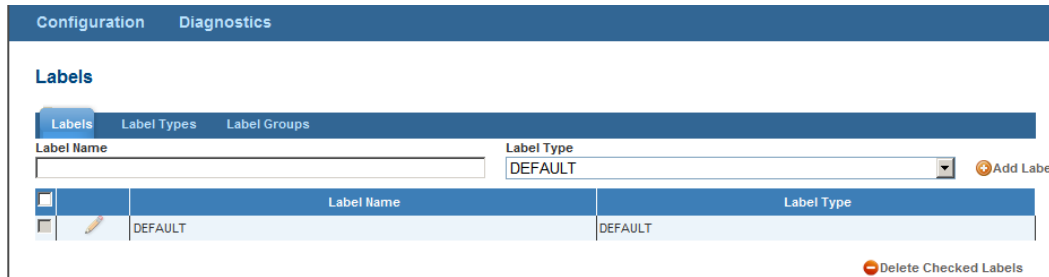



Figure 6.1: Labels Configuration Page

To add a label

1. Navigate to the Labels Configuration page. Configuration | Edit Logic | Edit Labels.
2. Type a unique Label Name. It can consist of alphanumeric characters and the underscore character.
3. Select a **Label Type**. If the label type you wish to associate with the label has not been created, leave the Label Type at Default. You can add the label to the appropriate label type when defining the desired Label Type.
4. Click **Add Label**. The new label is added to the table.

Once you have created a list of labels, you can sort the list by clicking on the column name of the field on which you wish to sort the list (Label Name or Label Type).

To edit a label

1. Click the **Edit Label** icon . The label row becomes editable, allowing you to change the name and select a different label type.

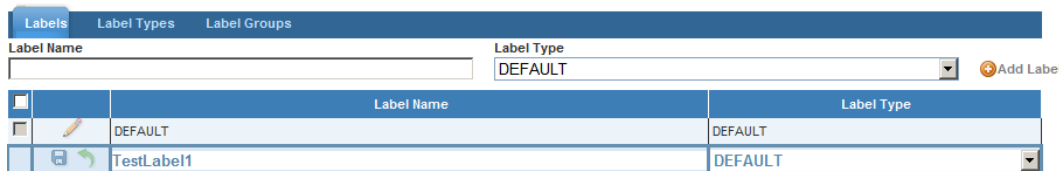

Figure 6.2: Labels Grid with Editable Row

2. Use the  to save the changes or click on  to cancel.

To delete a label

1. Select a label.
2. Click **Delete Checked Labels**.

Label Types

Label types are used to associate similar labels such as Shipping, UPC/EAN. With label types, labels that use similar data can have common label attributes and label lookups. Label type can be used to trigger the execution of a rule that applies to several labels.

The Label Type page allows you to add, edit, or remove label types. Every label configured for use with the Loftware Connector for SAP Applications requires an associated label type. Initially, only the read only **Default** label type is available.

Note: A Default label type can be used in rule assignments to indicate that the label type does not matter when deciding whether to invoke the filter.

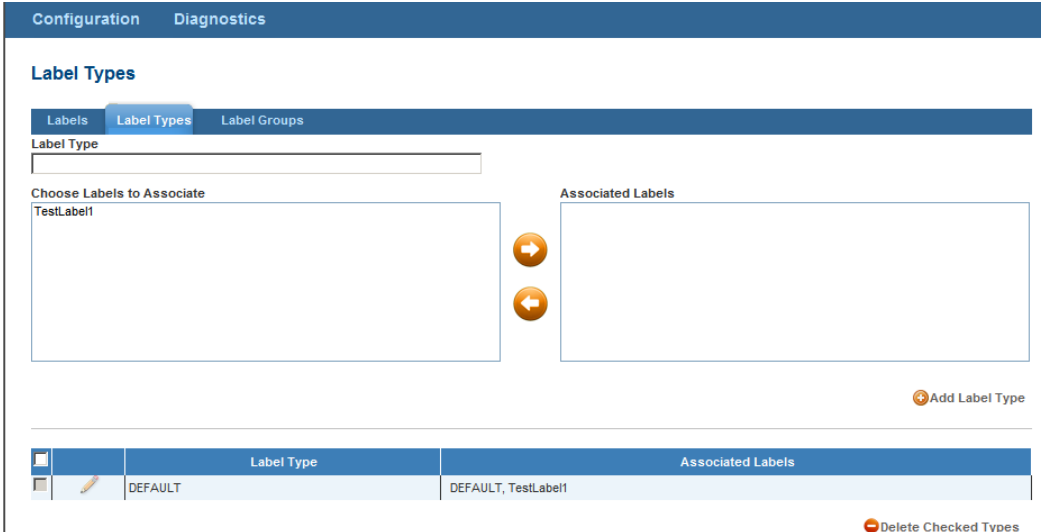

Configuration Diagnostics

Label Types

Labels **Label Types** Label Groups



Label Type

Choose Labels to Associate

TestLabel1

Associated Labels

+ Add Label Type

	Label Type	Associated Labels
 	DEFAULT	DEFAULT, TestLabel1



Figure 6.3: Label Types Page

To add a label type

1. Type a Label Type name. Label Type name must be unique. It can consist of alphanumeric characters and the underscore character.
2. Note that all defined labels are listed in the **Choose Labels to Associate** list. Select the label(s) you wish to associate with this label type by clicking.



Note: A Label Type can have several labels associated with it.

3. Click the right-arrow button to add the selected label(s) to the **Associated Labels** list. To remove labels from the list, click the left-arrow button.
4. Click the **Add Label Type** button. The new label type, along with the associated label(s), is added to the table.

Once you have created a list of label types, you can sort the list by clicking on the column name.

To edit a label type

1. Click the **Edit Type** button . The label type row becomes editable, allowing you to change the name and the labels to associate with it.

<input type="checkbox"/>		Label Type	Associated Labels
<input type="checkbox"/>		DEFAULT	DEFAULT
<input type="checkbox"/>		TestLabelType	TestLabel1



 Delete Checked Types

Figure 6.4: Label Types Table

2. Use the  to save the changes or click on  to cancel.

To delete a label type:

1. Select a label type by clicking on its check box.
2. Click **Delete Checked Types**. Respond to the confirmation message.

Labels associated with the deleted label type are assigned to the Default label type.

Label Groups

A Label Group allows labels to be organized and referred to with a single value during a print request using rules. For instance, a print request calling a Label Group name could print multiple different labels. The configuration will create a new label instance for each label assigned to the Label Group. A Label Group can be used in combination with either a Label or a Label Type in rule assignments to determine which filters to invoke.

Note: A Default label group can be used in rule assignments to indicate that the label group does not matter when deciding whether to invoke the filter.

Configuration Diagnostics

Label Groups

Labels Label Types **Label Groups**

Group Name

Choose Labels to Associate

TestLabel

Associated Labels

➔ Add Label Group

	Group Name	Associated Labels
<input type="checkbox"/>	DEFAULT	

⊖ Delete Checked Groups

To add a label group

1. Type in a label Group Name. Label Group Name must be unique. It can consist of alphanumeric characters and the underscore character.
2. All defined labels are listed in the **Choose Labels to Associate** box. Select the label(s) you wish to associate with this label group by clicking on it.

Note: A label can belong to more than one Label Group, and a Label Group can have several labels associated with it.

3. Click the right-arrow button to add the selected label(s) to the **Associated Labels** box. To remove a label, click the left-arrow button.
4. Click **Add Label Group**. The new label group, along with the associated label(s), is added to the label.

Once you have created a list of label groups, you can sort the list by clicking on the column name.

To edit a label group



1. Click the **Edit Group** button . The label group row becomes editable, allowing you to change the name and the labels to associate with the group.



Figure 6.5: Label Group Table

2. Use the  to save the changes or click  to cancel.

To delete a label group

1. Select a label group by clicking its check box.
2. Click **Delete Checked Groups**. Respond to the confirmation message.



Defining Rules

Loftware Connector for SAP Applications includes an extended Rules component that can be used to specify more complex label printing requirements, eliminating or reducing the need for custom label printing solutions and application modifications.

Rules can be used to find or add missing data to a request coming from an SAP transaction. Several items needed to create a valid print request may not be available to your program at the time that the request was made. Rules may be set up which will direct the Connector to retrieve or calculate any data that is missing from the request 'on-the-fly' at print time.

When the Loftware Connector for SAP Applications receives a print request, it will determine if a label or a label type, and/or a label group is associated with a rule. Depending on the rule type and the criteria provided at print time, the target printer or the label format can be selected, several label instances may be generated from one request, or fields can be added to the label. Rules can be used to filter, to extend, or to expand the fields that are printed, the LPS attributes that apply, or the label instances that they can be applied to.

Rule Types

Rule types, processed in order, are Printer Verification, Label Verification, Expansion, and Extension.

Printer Verification Rule Type

The Printer Verification rule is used to replace the LPS attribute value based on provided label data or other criteria. Refer to the "Printer Verification Rule Type" topic for more information.

Use the Printer Verification rule to replace the LPS attribute value based on provided data or other criteria. The LPS attribute "_PRINTERNAME" can only be updated by a Printer Verification rule. Other attributes include _JOBNAME, _PRINTERNAME, _TRAY, _QUANTITY, _DUPLICATES. (LPS attributes are described in the "Edit Criteria" topic.)

For example, a request to print labels can replace the _PRINTERNAME value with the SHIPPING printer based on certain label fields.

In this example, if Customer_ID=1234 AND PARTNUM=4444, then the job will be sent to the printer configured in LPS with the "Shipping" alias. If Customer_ID=4567 AND PARTNUM=B546, then the job will be sent to the printer with the "Customer Service" alias. (Criteria and Results are described in more detail in the Rule Lookups section.)



Criteria		Result
Customer_ID	PARTNUM	_PRINTERNAME
1234	4444	Shipping
4567	B546	Customer Service

Other examples:

- Change the quantity of labels needed based on the label type, customer ID, etc.
- Change the tray used in the printer to select a particular stock color for the document needed.

Label Verification Rule Type

The Label Verification is used to replace the _LABEL value based on provided label data or other criteria.

Use the Label Verification rule to replace the _LABEL value based on provided label data or other criteria. The LPS attribute “_LABEL ” can only be updated by a Label Verification rule.

After all Label Verification rules are completed, each requested Label must reference a valid Label Format file on a valid LPS. As part of Label Verification, the configuration will also retrieve a list of required fields for each Label.

For example, a request to print a shipping label can replace the _LABEL value to a customer-specific label based on customer ID.

In this example, the label is associated with a rule that has Customer_ID as criterion (input) and Shipping_Label as result (output). (Criteria and Results are described in more detail in the Rule Lookups section.)

label to print - shipping.lwl

Customer_ID (Criteria)	Shipping_Label (Result)
1234	kmart_label



Customer_ID (Criteria)	Shipping_Label (Result)
4567	target_label

Applying the rule, when Customer_ID is 1234, kmart_label is substituted for shipping.lwl. When Customer_ID is 4567, walmart_label is substituted for shipping.lwl.

Expansion Rule Type

The purpose of an Expansion rule is to expand a single label instance into multiple label instances. Use the Expansion rule to expand a single label instance into multiple label instances. It generates several label instances from a single request, creating separate labels for each item on an order. Expansion rules are processed in business logic, that is, they can only have a Logic result.

For example, a single print request for a 'Shipping' label could use an Expansion filter to print a shipping label for each item in the shipment.

Note: Loftware recommends that when using Extension or Expansion Rule Type, contact the Professional Services Group. Loftware Analysts can provide assistance with your specific configuration issues. For more information on PSG services, call PSG at 603-766-3630, email analyst@loftware.com, or visit the Loftware website www.loftware.com.

Extension Rule Type

The purpose of an Extension rule is to include additional data to an existing label instance.

Printer Verification, Format Verification, and Extension rules can use a Field or LPS result type or invoke business logic. Expansion rules must invoke business logic.

Use the Extension rule to extend the data passed in the print request by performing data lookups. This is used to simplify creation of the original request, or when the SAP system does not have access to some of the special data that a customer may require on their label.

For example, a print request is made that does not contain the data for origin or location, which are both required to print on the label. In this example, this information is stored in SAP (or in a different application) and can be looked up by using the data for the field LOT that is in the original print request.

Applying the rule in this example, if LOT=1, the values for ORIGIN=03801 and LOCATION=Portsmouth NH can be added to the printed label.



Note: Loftware recommends that when using Extension or Expansion Rule Type, contact the Professional Services Group. Loftware Analysts can provide assistance with your specific configuration issues. For more information on PSG services, call PSG at 603-766-3630, email analyst@loftware.com, or visit the Loftware website www.loftware.com.

Instance Extension Technologies

- Data lookups back to the SAP system may take the following forms:
 - Call any SAP-provided or custom RFC
 - Call any SAP-provided or custom BAPI
 - Query any SAP-provided or custom data dictionary table or view
- Data lookups to other systems may be made using SQL, Web Services, file transfer, or many other mechanisms
- Simple cross-reference lookups may be maintained directly in the Loftware Connector for SAP Applications.

Rule Criteria and Results

When the Loftware Connector for SAP Applications processes a print request, it first determines if the label is associated with a rule. Once it is determined that a rule is associated with the label, the configuration then decides whether the rule applies to the specific Label Instance by looking at defined criteria.

Note: If you want the rule to execute for ALL jobs, then do not add any criteria.

Criteria can be gathered from Loftware Print Server attributes, listed in the table below, and label fields. That is, field name, value pairs passed in the original print request or generated as the result of a previous filter.

Note: In the Loftware Print Server, `_FORMAT` is used instead of `_LABEL`.



Loftware Print Server Attributes

_LABEL	This is the name of the label designed in label design mode (Loftware Label Manager).
_JOBNAME	This names the job for status reporting purposes. If you do not name your job, it is displayed in the status view as the name of your xml file with an incrementing number. Using this setting allows you to find your job in the LPS Status Client or to check the status of a job through the Socket Interface.
_DEVTYPE	This is the family and model of the printer as defined in the Loftware device configuration. See the <i>Loftware Label Manager User's guide</i> for more information. The _DEVTYPE attribute is read only, so it can be used as rule criteria but not as rule results. The _DEVTYPE attribute will not return a result if used as rule criteria in a Printer Verification rule.
_PRINTERNAME	This is the printer alias as defined in the Loftware device configuration. See the <i>Loftware Label Manager User's Guide</i> for more information.
_QUANTITY	This specifies the quantity of labels to print.
_DUPLICATES	This specifies how many copies of the label to print. For example, you may need to put two labels on a box with the same serial number.
_PAGES	This specifies how many pages to print. This is only used if you are using a page layout for your label. See the <i>Loftware Label Manager User's Guide</i> for information on layouts.
_TRAY	This is available for laser printers only. If the printer you are printing to has more than one tray, this command is designed to send a label to a particular tray on the printer. The name MUST match the configured tray name in the driver setup (not case sensitive).

Criteria Matching

If there are multiple criteria, all criteria values must match the incoming job for the rule to apply. For example, in the criteria lookup row 1 example below, the rule will only apply to jobs with an Item_Num 1234 AND a Part_Num 4444.



<input type="checkbox"/>		Item_Num	Part_Num
<input type="checkbox"/>		1234	4444
<input type="checkbox"/>		1235	*
<input type="checkbox"/>		1236	

An asterisk can be used as a wild-card to indicate that any existing value will match. For row 2 above, the rule will apply to jobs that have an Item_Num 1235 AND any Part_Num.

A null value indicates that the value is missing. For row 3, the rule will apply to jobs that have an Item_Num 1236 AND Part_Num is null.

If there are no defined criteria, only one lookup row can be added, and the rule will apply to all assigned jobs.

Rule Results

Note: While a rule can be created without any Criteria, there must be at least one Result defined for a rule.

Based on the values of each criterion in the current Label Instance, in a print request, the configuration will look for match(es) in the result lookups. If there are no defined criteria, then all related result lookups are valid.

Result Type

Can be an LPS attribute, a label FIELD, or LOGIC.

- Results can update LPS attributes or label fields. Setting an LPS Attribute or Field will generate (if it doesn't exist) or override (if it does exist) the corresponding value on the Label instance.
- Using LOGIC will cause the configuration to look for a special Business Logic Transaction to run. This could be a lookup to an external system, for example.
- An Expansion rule can only have a Logic result.
- The LPS attribute “_PRINTERNAME” can only be updated by a Printer Verification rule.

Updating Results

The grid below shows the Results field PARTNUM with a value BR459. This rule will update the field PARTNUM to BR459 for every assigned job that the Connector processes. If there are no criteria defined, then the rule is applied to all jobs assigned to it. If there is no field called "PARTNUM" in the job, it will be created (Extension filter).

<input type="checkbox"/>		PARTNUM
<input type="checkbox"/>		BR549

The grid below will replace the _PRINTERNAME result with "Shipping1" (for jobs that match the 2 criteria). A blank cell value indicates that the _PRINTERNAME result should be left unchanged.

Rule Assignments		Rule Lookups		
Edit Grid Schema				
<input type="checkbox"/>		Item_Num	Part_Num	_PRINTERNAME
<input type="checkbox"/>		1234	4444	Shipping1
<input type="checkbox"/>		1235	*	

Define Rules

To add, edit, or remove rules, select Configuration | Edit Logic | Edit Rules. Initially, when there are no defined rules, only the **Add Rule** option is available on the Rules Overview page. Once rules are defined, this page will display a summary of all defined rules.

Configuration	Diagnostics
Rules Overview	
<input type="button" value="Remove Rule"/> <input type="button" value="Add Rule"/> <input type="button" value="Enable/Disable"/>	

Figure 7.1: Rules Overview Page

There are three elements to a rule definition:



- The **rule header** where the rule name, rule type, and other information are specified
- The **rule assignment** where the rule is assigned to a label, label type, or label group
- The **rule lookup** where criteria and result fields and lookups are specified or a business logic is invoked

Configuration Diagnostics

Add Rule

Rule Name:

Rule Type:

Enabled:

Comments:

Sequence:

Documentation Hyperlink Text:

Documentation Hyperlink Address:

Rule Assignments Rule Lookups

	Label	Label Type	Label Group
	<input type="text" value="DEFAULT"/>	<input type="text" value="DEFAULT"/>	<input type="text" value="DEFAULT"/>

Remove Assignment Add Assignment Save Rule

Figure 7.2: Add Rule Page

Defining a Rule

1. From the Rules Overview page, click **Add Rule** to define a new rule. To edit an existing rule, click on its **Rule Name**.
2. Type a **Rule Name**. It can consist of alphanumeric characters and the underscore character. The Rule Name must be unique.
3. Select a **Rule Type**.
4. Add optional **Documentation Hyperlink Address**. This Address can point to any supporting documentation for the rule.

Note: Documentation Hyperlink Text is required if a **Documentation Hyperlink Address** is entered. It can be any descriptive text which when clicked from the **Rules Overview** page will link to the document defined in the **Documentation Hyperlink Address**.

5. Select **True** from the **Enabled** drop-down field to turn on the rule. A rule that has **Enabled** set to **False** will not be used.

Note: Rules can also be enabled and disabled from the Rules Overview page.

6. Enter a **Sequence** number. This determines the order that the rules will be used within each Rule Type.

7. Add optional **Comments**. These can be instructions, descriptions, or comments.

8. Click **Add Assignments**, and then click the Edit Rule Assignment button .

9. Select a Label, Label Type, and Label Group to the rule, and click the Save icon . At least one label must be assigned to the rule.

Note: The assigned label can be the default label.

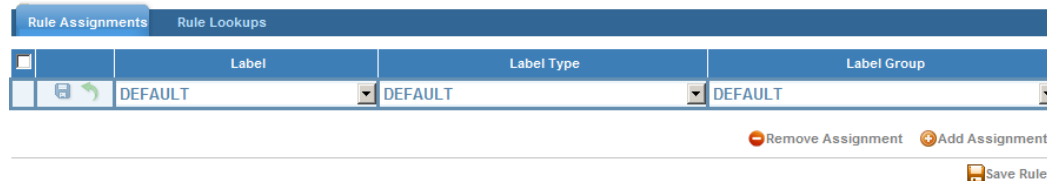

The screenshot shows the 'Rule Assignments' tab selected. It features a table with columns for 'Label', 'Label Type', and 'Label Group'. Each column contains a dropdown menu with 'DEFAULT' selected. Below the table are three buttons: 'Remove Assignment' (with a minus icon), 'Add Assignment' (with a plus icon), and 'Save Rule' (with a floppy disk icon).

Figure 7.3: Rule Assignment Section

10. Click **Save Rule** to save the current settings for the new rule. This will open the **Rules Overview** page where the new rule will be listed.

11. Select the **Rule Lookups** tab.



The screenshot shows the 'Rule Lookups' tab selected. It features a table with columns for 'Label', 'Label Type', and 'Label Group'. Below the table are three buttons: 'Remove Lookup' (with a minus icon), 'Add Lookup' (with a plus icon), and 'Save Rule' (with a floppy disk icon). There is also an 'Edit Grid Schema' button with a pencil icon.

12. Click **Edit Grid Schema**. The Edit Criteria Schema window opens.

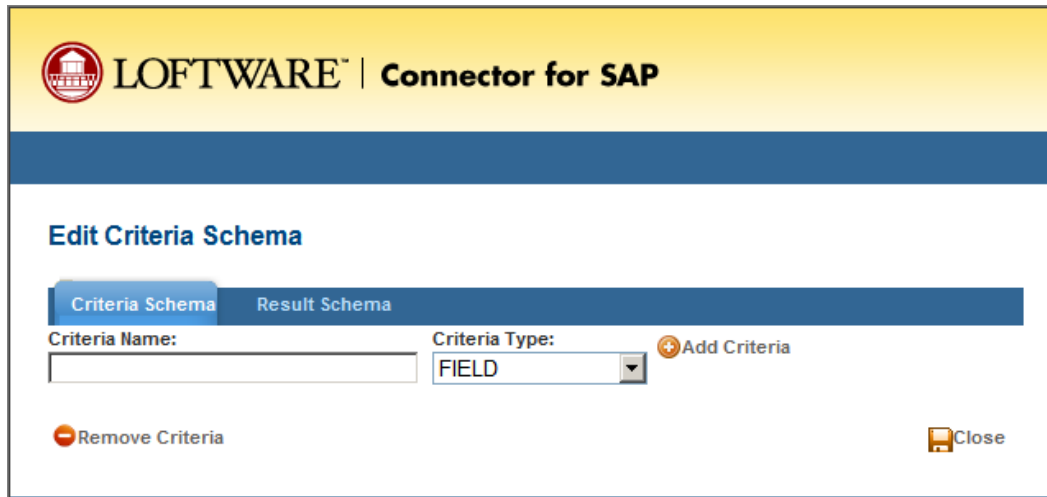





Figure 7.4: Edit Criteria Schema Window

13. Add, edit, or delete criteria (input) or result (output) schema for the rule.
 - a. Type the **Criteria Name**. The name can use alphanumeric characters and the underscore. Criteria Name must be unique within the rule.
 - b. For **Criteria Type**, select FIELD if the criterion is taken from a field on the label. Select LPS if the criterion is an LPS attribute, for example, _PRINTERNAME, _LABEL, _JOBNAME, _QUANTITY, _DUPLICATES, _PAGES, _TRAY.
 - c. Click **Add Criteria** to add the criterion.
 - d. Repeat steps a to c to add additional criteria.

Note: There is a limit of three criteria per rule.

Criteria Name: Criteria Type:  Add Criteria

<input type="checkbox"/>		Criteria Name	Criteria Type
<input type="checkbox"/>		Test_Field_1	FIELD
<input type="checkbox"/>		Test_Field_2	FIELD



 Remove Criteria  Close

Figure 7.5: Criteria List

See the Adding Criteria and Results Lookups topic for more information on Criteria matching.

- Click the **Result Schema** tab to define the results schema for the rule.



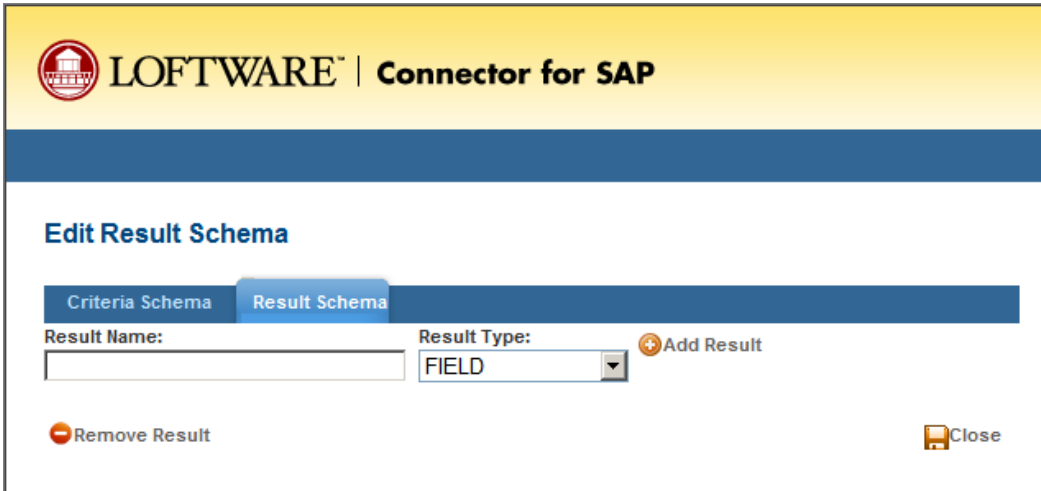

LOFTWARE | Connector for SAP

Edit Result Schema

Criteria Schema **Result Schema**

Result Name: Result Type:  Add Result

 Remove Result  Close

- Type the Result Name. The name can consist of alphanumeric characters and the underscore character. Result Name must be unique within the rule.
- Select the **Result Type**.

See the Rule Criteria and Results topic for a description of these LPS attributes.

17. Once you have defined criteria and results for the rule, click **Close**.

Adding Criteria and Results Lookups



When the **Add Rule** page is redisplayed after criteria and results schema is specified, values for criteria and results can be specified by adding lookups.

To add a lookup

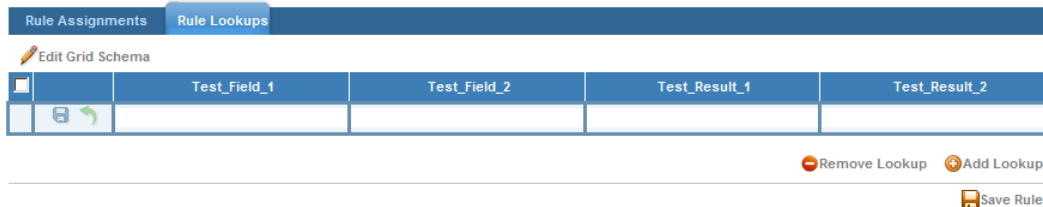
1. From the **Edit Rule** page, click **Add Lookup**. A row is added for defining the values for the criteria and results.
2. Click Edit , and enter values



	Test_Field_1	Test_Field_2	Test_Result_1	Test_Result_2
				

 Remove Lookup
  Add Lookup
 Save Rule



3. Click Save  to save the lookup.
4. Repeat steps 1 to 3 to define additional lookups.

Saving the Rule

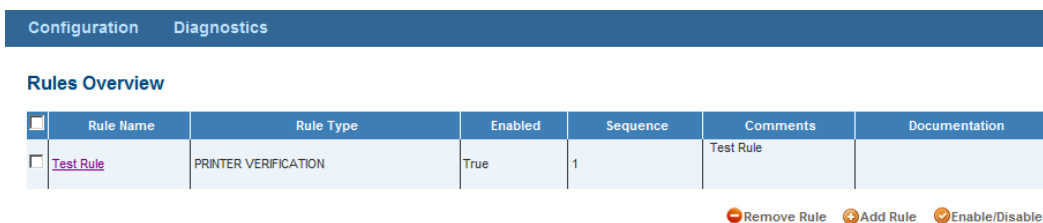
- Click **Save Rule**. Once a rule is created and saved, it is added to the **Rules Overview** page.
- To edit a rule, click the **Rule Name**.



	Rule Name	Rule Type	Enabled	Sequence	Comments	Documentation
<input type="checkbox"/>	Test Rule	PRINTER VERIFICATION	True	1	Test Rule	

 Remove Rule
  Add Rule
  Enable/Disable

From the **Rules Overview** page, defined rules can be deleted, enabled or disabled. If documentation was specified for a rule, clicking on the hyperlink text will link you to the documentation (if the link is valid).

Edit Servers

The Servers Overview window allow you to view server, device, and label information that is stored in the ProvDa database.

Remove a server from the database

It may become necessary to remove a server.

1. Select the server.
2. Click **Clear Server**, and click **OK** to confirm.

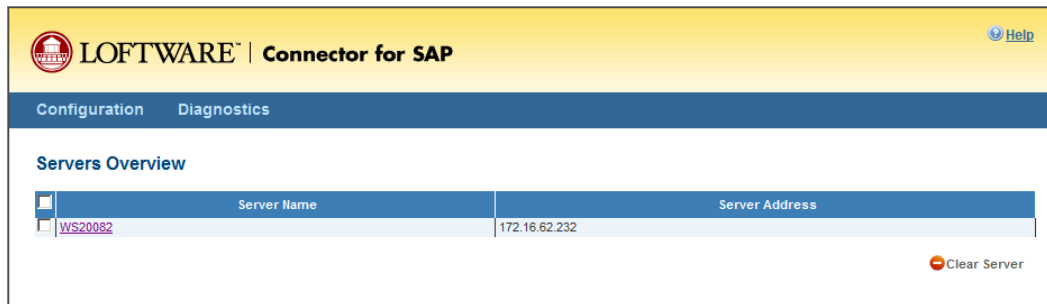

Figure 7.6: Servers Overview Window

View the available devices for a server

1. Under **Server Name**, click the name of the server.
2. Click **Devices**.



Number	Type	ID	Port	Name
1	Loftware Zebra ZM400 (ZPL)	3510	LPT1:	Zebra1
2	Loftware Zebra ZM400 (ZPL)	3510	LPT2:	Zebra2
3	Microsoft XPS Document Writer	0	Ne00:	Microsoft XPS Document Writer

Figure 7.7: Devices Window

View the available labels for a server

1. Under **Server Name**, click the name of the server.
2. Click **Labels**.

Name	Path	Label Device	Device ID	Type	Group
1724Asdk.lwl	\\symbol	Device Not Configured	3129	DEFAULT	DEFAULT
AIAGSAMP.LWL	\\SAMPLES\INTERMEC\	Device Not Configured	3009	DEFAULT	DEFAULT
ALabel1.lwl	\\	Loftware Zebra ZM400 (ZPL)	3510	DEFAULT	DEFAULT
ALabel1Preview.lwl	\\	Microsoft XPS Document Writer	0	DEFAULT	DEFAULT
ALabel2.lwl	\\	Loftware Zebra ZM400 (ZPL)	3510	DEFAULT	DEFAULT
AUTOTECH.lwl	\\symbol	Device Not Configured	3129	DEFAULT	DEFAULT
BLabel1.lwl	\\	Loftware Zebra ZM400 (ZPL)	3510	DEFAULT	DEFAULT
BLabel1Preview.lwl	\\	Microsoft XPS Document Writer	0	DEFAULT	DEFAULT
BLabel2.lwl	\\	Loftware Zebra ZM400 (ZPL)	3510	DEFAULT	DEFAULT
BoxCount.lwl	\\SAMPLES\	Device Not Configured	3073	DEFAULT	DEFAULT

Figure 7.8: Labels Metadata Window



System Configuration

You can use the System Configuration page to set the following:

- The External System Number
- The SAP Callback
- The ROM S

The Loftware Connector for SAP Applications supports connection to up to three SAP instances.

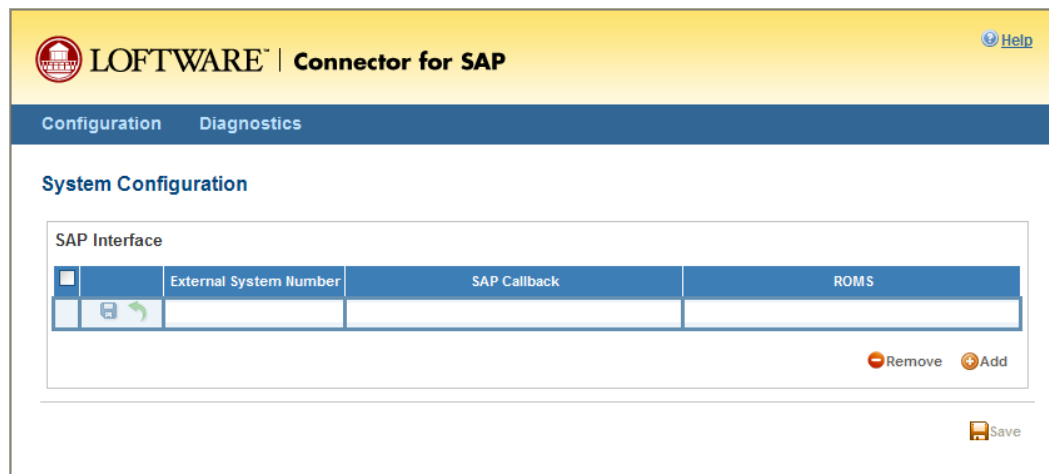





Figure 7.9: System Configuration Page

To Add SAP Interface Connections

The Loftware Connector for SAP Applications supports connection to up to three SAP instances.

1. From the System Configuration page, click the **Edit SAP Callback** button .
2. Enter the **External System Number**, the **SAP Callback**, and the **ROM S**.
3. Click the **Save Change** button .
4. To add additional SAP Callbacks, click **Add**, and repeat the previous steps.
5. Click  **Save**.

Format Path Definition

The Edit Format Path Definition page is used to define a dynamic path to Loftware Print Server resources. The Loftware Connector for SAP Applications uses **Path Elements** that you define to create the path. When the Loftware Connector for SAP Applications sends a print job to the Loftware Print Server, the defined path is appended to the label name from the job.

Note: Before editing the Format Path Definition, verify that you have installed the latest critical updates through Windows Update. Check specifically for the following update:
Microsoft .NET Framework 3.5 Service Pack 1 and .NET Framework 3.5 Family Update for .NET versions 2.0 through 3.5 (KB951847) x86

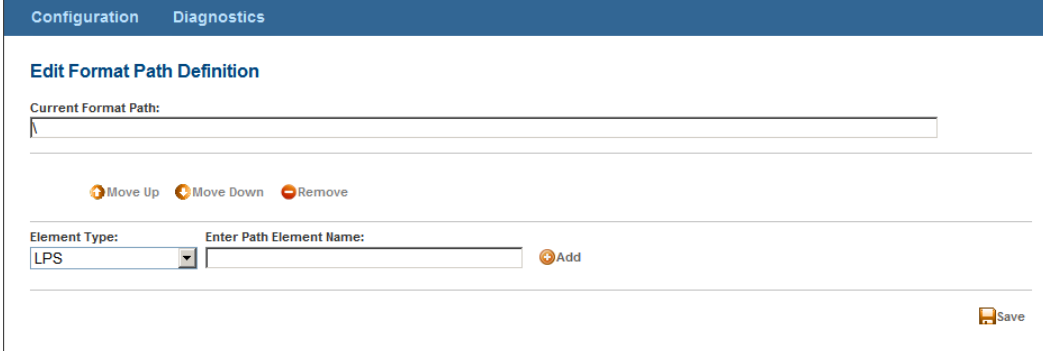

The screenshot shows the 'Edit Format Path Definition' page in a web application. At the top, there are tabs for 'Configuration' and 'Diagnostics'. The main heading is 'Edit Format Path Definition'. Below this, there is a text input field labeled 'Current Format Path:'. Underneath the input field are three buttons: 'Move Up', 'Move Down', and 'Remove'. Below these buttons is a section for adding new path elements. It includes a dropdown menu for 'Element Type:' with 'LPS' selected, a text input field for 'Enter Path Element Name:', and an 'Add' button. At the bottom right of the form area is a 'Save' button.

Figure 7.10: Edit Format Path Definition

You define the path using elements. The following Element Types can be used:

- LPS - Loftware Print Server attributes.
- Field - A label field name. Use valid field name characters
- Literal - Text. Use valid path characters

Note: LPS attributes and field names may contain characters that are invalid in paths. For example: / * ? " < > |.

Related Information

See the [Rule Criteria and Results](#) topic for a list of Loftware Print Server attributes that can be used in Format Path definitions.

Defining a Format Path

1. Select **Edit Format Path** from the **Configuration** menu.
2. Select a type from the **Element Type** field.
3. Enter the name of the Element in the **Enter Path Element Name** field, and click **Add**. The element name is added to the **Current Format Path** field in brackets, indicating that the value is variable.

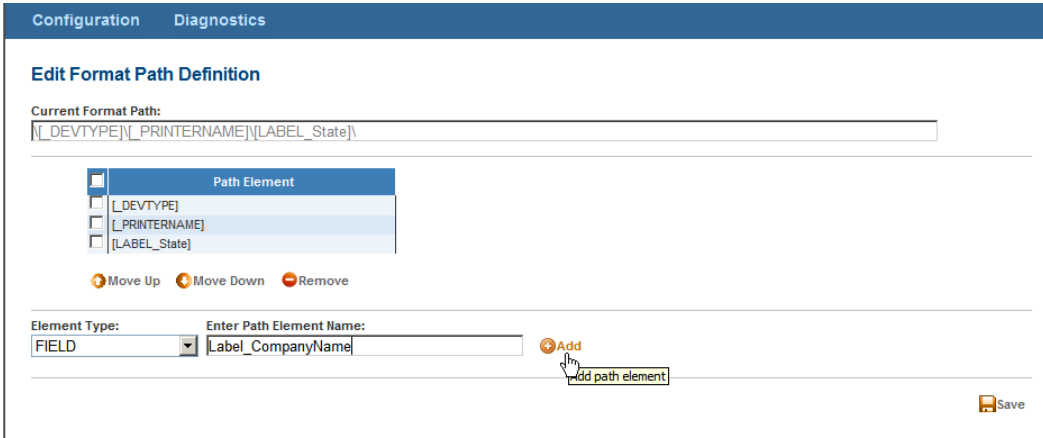

The screenshot shows the 'Edit Format Path Definition' interface. At the top, there are tabs for 'Configuration' and 'Diagnostics'. The main title is 'Edit Format Path Definition'. Below this, the 'Current Format Path' field contains the text: `[_DEVTYPE][_PRINTERNAME][LABEL_State]`. Underneath is a 'Path Element' list with three items: `[_DEVTYPE]`, `[_PRINTERNAME]`, and `[LABEL_State]`. Below the list are three buttons: 'Move Up', 'Move Down', and 'Remove'. At the bottom, there are two input fields: 'Element Type' (set to 'FIELD') and 'Enter Path Element Name' (containing 'Label_CompanyName'). To the right of the second field is an 'Add' button with a tooltip that says 'Add path element'. In the bottom right corner, there is a 'Save' button.

Figure 7.11: Edit Format Path Definition with Field Element

4. Click **Save**.

Processing a Print Request

When the Loftware Connector for SAP Applications receives a print request, it examines the LABEL value on each label instance in the print request. For example, if the LABEL value is a Label Group, the Loftware Connector for SAP Applications will determine if it consists of any Label or Label Type(s).

The configuration will then check for all rules for each of the label instances, starting with printer verification, then label verification, expansion, and extension. If there is more than one rule that applies within a rule type, they are processed according to a defined sequence order.

Once the rules that apply are determined, the configuration will examine the criteria specified for the rule. The rule criteria are examined, if they exist. If there are any criteria defined for the rule (up to 3 per rule), they must all be met for the rule to apply. If the criteria are met, the configuration will look for matches in the result lookups. If there are no criteria, then the rule applies and all matches in the result lookups are valid.

Diagnostics

The Diagnostics page displays information on the status of the Loftware Print Server , Loftware Connector for SAP Enterprise Update, and Connector services.

- View status of the Loftware Connector for SAP Applications components
- View components and their versions
- View log files
- Test print a file
- Save Log Files

Components

The Status of the components of the Loftware Connector for SAP Applications is displayed in the Status section of the Diagnostics page.

Status
✓ Connector for SAP
✓ Loftware Print Server
✓ Loftware Enterprise Update Service

Figure 7.12: Status Section of Diagnostics Page

The individual Components, along with their version and modified date, is displayed in the Components section of the Diagnostics page.

Components		
Component Name	Date	Version
Loftware Connector for SAP	9/28/2010	2.0.0.0
Loftware Connector for SAP Configuration	9/28/2010	2.0.0.0
Loftware Connector for SAP Enterprise Update	9/28/2010	2.0.0.0
Loftware Connector for SAP Server	9/23/2010	4.2.1.193
Loftware Print Server	9/3/2010	9.8.0.0
ProvDa	9/28/2010	1.7.2.0
Rudy	9/28/2010	2.0.2.0

Figure 7.13: Components Section of Diagnostics Page

Log Files

Use the View button to display a popup window with the desired log file.







File	View
Connector for SAP Interface Log	
Connector for SAP RFC Listener Error Log	
Loftware Enterprise Update Utility Log	
Connector for SAP Configuration UI Log	
ProvDa Cache Reset Log	
Rudy Cache Reset UI Log	

Figure 7.14: Log Files Section of Diagnostics Page



Log File Descriptions

- Connector for SAP Interface log is a transactional log that tracks file processing.
- Connector for SAP RFC Listener Error log lists errors that occur in the Connector SAP RFC Listener.
- Loftware Connector for SAP Enterprise Update Utility log keeps track of LWEntUp activities.
- Connector for SAP Configuration UI Log tracks Configuration UI activities.
- Provda Cache Reset Log tracks changes to the Provda data.
- Rudy Cache Reset UI Log tracks changes to the rules database.

Log files can be viewed and saved. An example log file is shown below.



sap_interface.log

```
10/01/10 14:34:11 NLINK Server version 4.2.1.193 started at 10/01/10 14:34:08
10/01/10 14:34:11 [Session Id 0] [Interface - Clear Local Keys and Cache
(provda)] [INFO] Local rules cache reset (provda)
10/01/10 14:34:11 [Session Id 1] [Interface - Clear Local Keys and Cache
(rudy)] [INFO] Local rules cache reset (rudy)
10/04/10 10:21:57 [Session Id 0] [Interface - Clear Local Keys and Cache
(rudy)] [INFO] Local rules cache reset (rudy)
10/04/10 11:07:56 [Session Id 0] [Interface - Clear Local Keys and Cache
(rudy)] [INFO] Local rules cache reset (rudy)
10/04/10 11:08:43 [Session Id 0] [Interface - Clear Local Keys and Cache
(rudy)] [INFO] Local rules cache reset (rudy)
10/04/10 11:54:57 [Session Id 0] [Interface - Clear Local Keys and Cache
(rudy)] [INFO] Local rules cache reset (rudy)
10/04/10 16:21:37 [Session Id 0] [Interface - Clear Local Keys and Cache
(rudy)] [INFO] Local rules cache reset (rudy)
10/04/10 16:36:08 [Session Id 0] [Interface - Clear Local Keys and Cache
(rudy)] [INFO] Local rules cache reset (rudy)
10/05/10 09:14:40 [Session Id 0] [Interface - Clear Local Keys and Cache
(rudy)] [INFO] Local rules cache reset (rudy)
10/05/10 10:26:05 [Session Id 0] [Interface - Clear Local Keys and Cache
(rudy)] [INFO] Local rules cache reset (rudy)
10/05/10 10:27:16 [Session Id 0] [Interface - Clear Local Keys and Cache
(rudy)] [INFO] Local rules cache reset (rudy)
10/05/10 13:51:17 [Session Id 0] [Interface - Clear Local Keys and Cache
(rudy)] [INFO] Local rules cache reset (rudy)
```

 Save As...

Figure 7.15: Example SAP Connector Log File

Save Log Files

1. From the Diagnostics page, click **Save As** to save a log file.
2. Type a name for the log file, and click **Save**.

To save and extract log files

1. Select Loftware Log Files from the File Types to Retrieve drop-down list. Click **Retrieve**.
2. From the File Download dialog, click on Save. Browse to the folder where you wish to save the file. Click **Save**.
3. To view the zipped log file, make sure the File Types to Retrieve list is set to Loftware Log Files. Click **Retrieve**.
4. From the File Download dialog, click **Open**.
5. Enter the full name for the file. For example, if you give the file a .doc extension, the file when extracted can be viewed using Word. Click **OK**.

Note: that the doc file is now listed in the zip file.



6. Select the doc file and click **Extract**. Browse to the folder where you wish to save the extracted file, and then click **Extract**.

Note: Be aware that currently, LwEntUp.log is not included in the Loftware Log Files concatenated log file. To work around this issue, view the "Loftware Enterprise Update Utility Log" (Log Files section of the Diagnostics page) and then click on Save As to save the file.

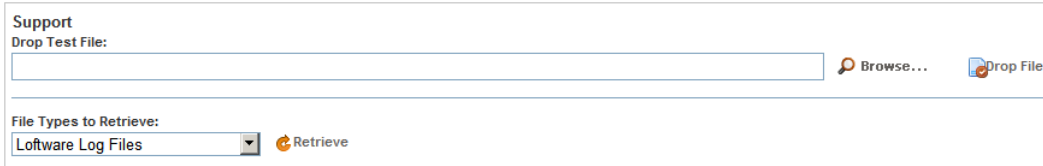
From the Diagnostics page, use the Drop Test File **Browse** button to locate a file to test print, and then click **Drop File** to drop the file to the Connector drop folder for processing.



Support
Drop Test File:

File Types to Retrieve:
 

Figure 7.16: Support Section of Diagnostics Page



In the example below, an XML file uses a label called shipping.lwl. A Printer Verification rule has been defined for the file. The SHIP_ZIP value will determine whether to substitute "Shipping" for the current _PRINTERNAME value (Printer1).

	SHIP_ZIP	_PRINTERNAME
	44118	Shipping

```
<?xml version="1.0" standalone="no" ?>
<!DOCTYPE labels SYSTEM "C:\Program Files\Loftware Labeling\batch\label.dtd">
<labels _FORMAT="shipping.LWL" _JOBNAME="SampleJob001" _QUANTITY="1" _PRINTERNAME="Printer1">
  <label>
    <variable name="FROM1">ABC Manufacturing</variable>
    <variable name="FROM2">110 Main Street</variable>
    <variable name="FROM3">Portsmouth, NH 03801</variable>
    <variable name="COMPANY">Acme</variable>
    <variable name="TO_1">123 West St.</variable>
    <variable name="TO_2">Cleveland, OH 44118</variable>
    <variable name="SHIP_ZIP">44118</variable>
    <variable name="BARCODE">09254658907859513895</variable>
  </label>
  <label>
    <variable name="FROM1">ABC Manufacturing</variable>
    <variable name="FROM2">110 Main Street</variable>
    <variable name="FROM3">Portsmouth, NH 03801</variable>
    <variable name="COMPANY">Widgets, Inc</variable>
    <variable name="TO_1">110 Bridge St.</variable>
    <variable name="TO_2">Lowell, MA 01852</variable>
    <variable name="SHIP_ZIP">01852</variable>
    <variable name="BARCODE">32584892735615890508</variable>
  </label>
  <label>
    <variable name="FROM1">ABC Manufacturing</variable>
    <variable name="FROM2">110 Main Street</variable>
    <variable name="FROM3">Portsmouth, NH 03801</variable>
    <variable name="COMPANY">XYZ Co.</variable>
    <variable name="TO_1">234 Pine Hill Rd.</variable>
    <variable name="TO_2">Dallas, TX 75201</variable>
  </label>
</labels>
```



```
<variable name="SHIP_ZIP">75201</variable>
<variable name="BARCODE">12658463589243245694</variable>
</label>
<label>
  <variable name="FROM1">ABC Manufacturing</variable>
  <variable name="FROM2">110 Main Street</variable>
  <variable name="FROM3">Portsmouth, NH 03801</variable>
  <variable name="COMPANY">Colorful Widgets</variable>
  <variable name="TO_1">1022 Hickerson Rd</variable>
  <variable name="TO_2">South Euclid, OH 44118</variable>
  <variable name="SHIP_ZIP">44118</variable>
  <variable name="BARCODE">13564865972564865213</variable>
</label>
</labels>
```

In this example, the first and the last labels defined in the file meet the rule criteria (SHIP_ZIP = 44118) and when printed will use the printer defined as "Shipping" in the LPS ("Shipping" replaces "Printer1").